

## E-821.EHD Piezoelectric Energy Harvesting Evaluation Kit

### Documentation

- User Manual E821T0002 (this document)
- Datasheets for E-876.A12 DuraAct patch transducers and E-821.00 modules for energy harvesting
- Whitepaper “Energy Harvesting Uses The Piezo Effect”

For the motivation and possible applications of energy harvesting with piezoelectric transducers see the whitepaper in the appendix of this document.

To ease a first integration of DuraAct transducers PI Ceramic offers the E-821.EHD evaluation kit. With this, you may try to integrate the PI Ceramic solution in your application, and see if it may work for you.

### Scope of Delivery

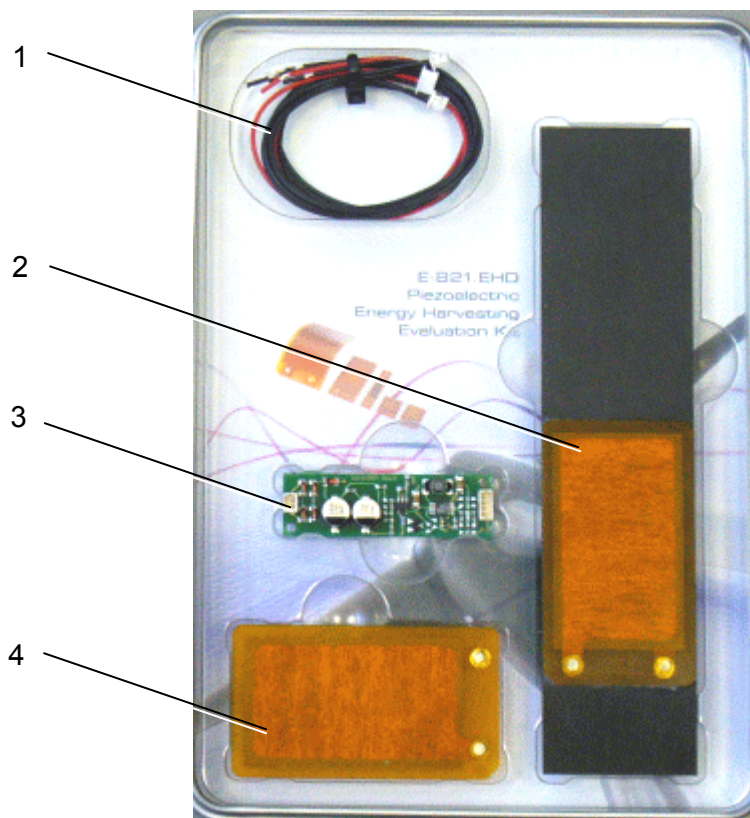

**1** Cable set:

- 2 x K040B0428 for connection of P-876.A12 to E-821.00
- 1 x K040B0429 for connection of the electrical load to E-821.00

**2** P-876KEHD consisting of a P-876.A12 DuraAct patch transducer glued to a plate made of carbon fiber reinforced plastic

**3** E-821.00 module for energy harvesting

**4** P-876.A12 DuraAct patch transducer

## Mounting the DuraAct Patch Transducer

The E-821.EHD kit contains two P-876 DuraAct patch transducers in different integration states to offer you greatest flexibility for mounting:

- One single patch transducer for gluing on a surface (P-876.A12)
- One patch transducer glued on a plate which must be clamped (P-876KEHD)

Irrespective of the kind of mounting, the bending radius must **not** be less than 20 mm for the P-876.A12 DuraAct patch transducers.

### Gluing a P-876.A12 Patch Transducer on a Surface

Recommended adhesive: two-component epoxy

- Roughen the surfaces before gluing.
- Make sure to glue the complete surface.

### Clamping the P-876KEHD Plate

- Chamfer the ends of the clamping bar which point to the plate to avoid a notch effect, see figure below.
- Clamp the plate at the short end as near as possible to the DuraAct patch transducer, see figure below.
  - Clamping depth: minimum 10 mm
  - Clamping width: 35 mm (i.e. clamping over the complete width of the plate)

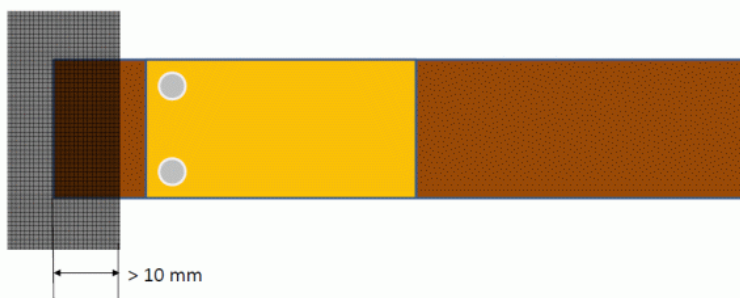
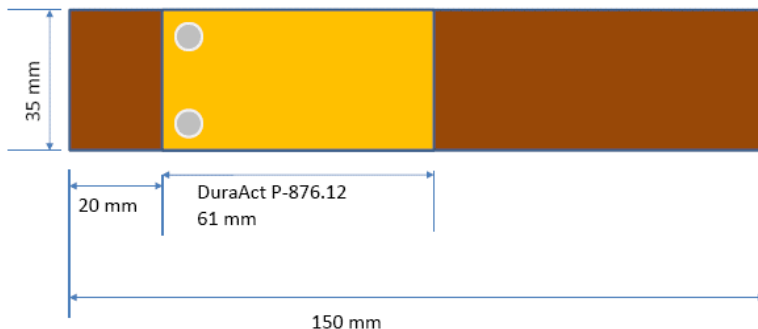

## Connecting DuraAct Patch Transducer and Electrical Load to the E-821.00 Module

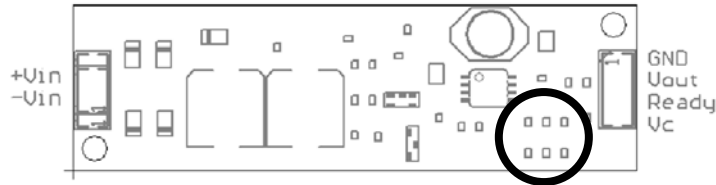

Fig. 1: E-821.00 module; location of the soldering points for output voltage selection marked by circle

### Input Signals of the E-821.00 Module

2-pin Molex PicoBlade connector

Pins	Values	Notes
+V <sub>in</sub>	max. 40.0 V,	Input voltage from DuraAct patch transducer, both AC or DC possible
-V <sub>in</sub>	internal limit 15 V	

### Output Signals of the E-821.00 Module

4-pin Molex PicoBlade connector

Pins	Values	Notes
GND	-	-
V <sub>out</sub>	3.3 V	Output voltage, regulated Can be changed to 1.8 V or 5.0 V by relocating the 0-ohm solder bridge between the corresponding soldering points.
Ready	0 V or 9 to 12 V	Output voltage which indicates the charge state of the capacitor of the E-821.00: <ul style="list-style-type: none"> <li>0 V if the charge state of the capacitor is not sufficient to output V<sub>out</sub></li> <li>9 to 12 V if the capacitor outputs V<sub>out</sub></li> </ul> Output impedance: 1 kOhm Can be used to switch the connected load on or off.
V <sub>c</sub>	5.0 to 40.0 V	Rectified output voltage of storage capacitor

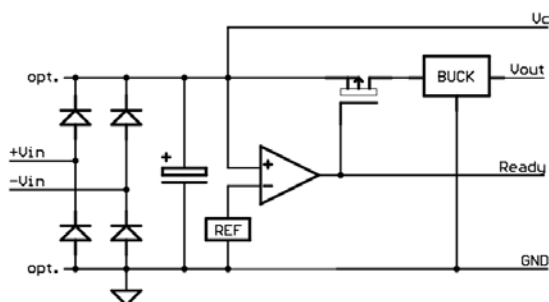
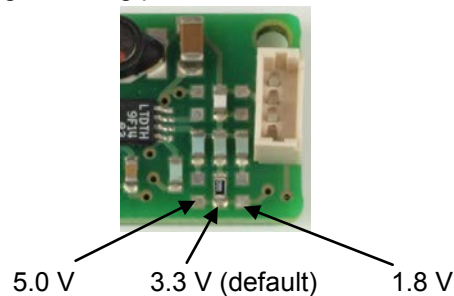

Fig. 2: Block diagram for E-821.00 module

### Connecting the Patch Transducer to the E-821.00 Module for Energy Harvesting

For each DuraAct patch transducer, a K040B0428 cable with 2-pin Molex PicoBlade socket and open wires is included in the scope of delivery.

- Solder the two open wires of the K040B0428 cable to the two solder points of the DuraAct patch transducer. Any assignment is possible due to the non-polarized (AC) output of the DuraAct patch transducer (is rectified by the E-821.00 module).
- After soldering, it is recommended to cover the solder points on the DuraAct patch transducer with electrical tape.
- Connect the DuraAct patch transducer to the E-821.00 module via the 2-pin Molex PicoBlade socket.

### Connecting the Electrical Load to the E-821.00 Module for Energy Harvesting

For the connection of the electrical load (in short form: „load“; i.e. the consumer) to the E-821.00 module, the K040B0429 cable with 4-pin Molex PicoBlade socket and open wires is included in the scope of delivery. With the K040B0429 cable, the load is supplied by the  $V_{out}$  output voltage of the E-821.00 module.

Example for a load: low-power microcontroller

- Solder the two open wires of the K040B0429 cable to the load. Respect the output polarity indicated by the wire color:

Pin	Color
GND	Black
$V_{out}$	Red

- Connect the load to the E-821.00 module via the 4-pin Molex PicoBlade socket.

Note: If the load requires a supply voltage higher than  $V_{out}$ , you can use the  $V_c$  output voltage instead of  $V_{out}$ . In this case, make sure that the load is switched on/off using the signal provided by the Ready pin of the E-821.00 module to avoid unwanted discharge of the capacitor. You have to design a custom cable for connection to the  $V_c$  and Ready pins of the E-821.00 module.

### Operation

To generate an input voltage for the E-821.00 module and thus charge the capacitor, the DuraAct patch transducer must be mechanically deformed by force applied with tension or pressure (“excitation”). The bending radius must **not** be less than 20 mm for the P-876.A12 DuraAct patch transducers.

For the power output of the E-821.00 as a function of the excitation conditions see the whitepaper in the appendix of this document. Note that the measurements described in the whitepaper were made with a P-876.A12 glued to a plate which was more flexible than the plate used for P-876KEHD in the scope of delivery.

- Perform a first test without load. For this test, use the P-876KEHD combination of DuraAct patch transducer and plate:
  1. Make sure that the plate is clamped as described on p. 2.
  2. Make sure that the DuraAct patch transducer is connected to the 2-pin connector of the E-821.00 module as described above.
  3. Connect an oscilloscope to the  $V_{out}$  pin of the E-821.00 module.
  4. Excite the DuraAct patch transducer by tipping the plate or picking at the plate with your fingers at least 10 times. After at least 10 excitation cycles, the oscilloscope should measure 3.3 V for at least 5 s (output duration can be influenced by the input impedance of the measurement device).

Note that the  $V_{out}$  voltage is output by the E-821.00 module only if the charge state of the capacitor is sufficient (switching the output on/off is based on an internal threshold).

The following reasons can cause the test to fail (i.e. no voltage can be measured):

- Number of excitation cycles is too low.
- Force applied for mechanical deformation is too low.

If the test without load was successful but supplying a load fails, the load may be too high.

The E-821.00 module can be adapted to your application as follows:

- Change the  $V_{out}$  output voltage to 1.8 V or 5.0 V as described on p. 3
- If a different input voltage range is necessary, contact your PI Ceramic sales engineer for appropriate modification of the E-821.00 module.

### Technical Data

See the data sheets in the appendix of this document for the technical data of the P-876.A12 DuraAct patch transducers and the E-821.00 module for energy harvesting.

# DuraAct Patch Transducer

BENDABLE AND ROBUST

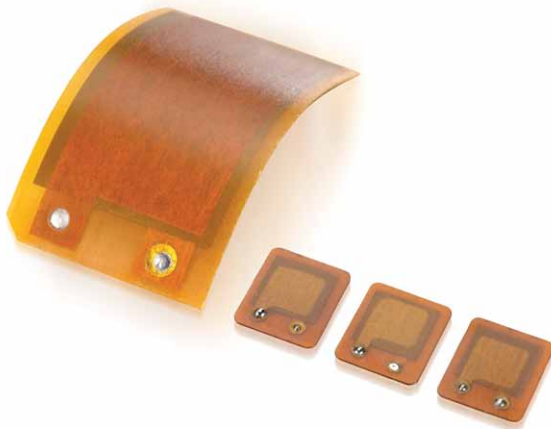

## P-876

- Use as actuator, sensor or energy generator
- Cost-effective
- Min. bending radii of down to 12 mm

### Patch transducer

Functionality as actuator and sensor component. Nominal operating voltage from 100 up to 1000 V, depending on the active layer height. Power generation for self-sufficient systems possible up to the milliwatt range. Can also be applied to curved surfaces

### Robust, cost-effective design

Laminated structure consisting of a piezoceramic plate, electrodes and polymer materials. Manufactured with bubble-free injection method. The polymer coating simultaneously serves as a mechanical preload as well as an electrical insulation, which makes the DuraAct bendable

### Custom DuraAct patch transducers

- Flexible choice of size
- Flexible choice of thickness and thus bending ability
- Flexible choice of piezoceramic material
- Variable design of the electrical connections
- Combined actuator/sensor applications, even with several piezoceramic layers
- Multilayer piezo elements
- Arrays

### Fields of application

Research and industry. Can also be applied to curved surfaces or used for integration in structures. For adaptive systems, energy harvesting, structural health monitoring

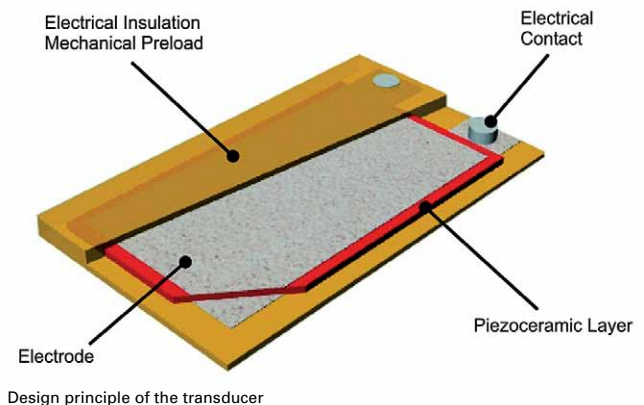

Design principle of the transducer

### Valid patents

German Patent No. 10051784C1  
US Patent No. 6,930,439

### Suitable drivers

E-413 DuraAct and PICA Shear Piezo Amplifier  
E-835 DuraAct Piezo Driver

Order Number	Operating voltage [V]	Min. lateral contraction [ $\mu\text{m}/\text{m}$ ]	Rel. lateral contraction [ $\mu\text{m}/\text{m}/\text{V}$ ]	Blocking force [N]	Dimensions [mm]	Min. bending radius [mm]	Piezo ceramic height [ $\mu\text{m}$ ]	Electrical capacitance [nF] $\pm 20\%$
P-876.A11	-50 to +200	400	1.6	90	61 × 35 × 0.4	12	100	150
P-876.A12	-100 to +400	650	1.3	265	61 × 35 × 0.5	20	200	90
P-876.A15	-250 to +1000	800	0.64	775	61 × 35 × 0.8	70	500	45
P-876.SP1	-100 to +400	650	1.3	280	16 × 13 × 0.5	-	200	8

Piezo ceramic type: PIC 255

Standard connections: Solder pads

Operating temperature range: -20 to 150°C

Custom designs or different specifications on request.

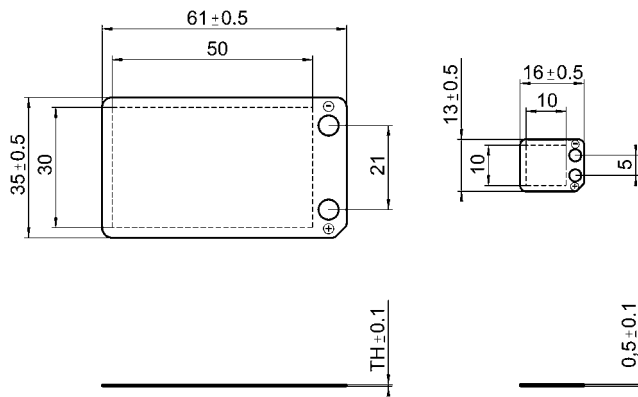

P-876.A (left), P-876.SP1 (right), dimensions in mm

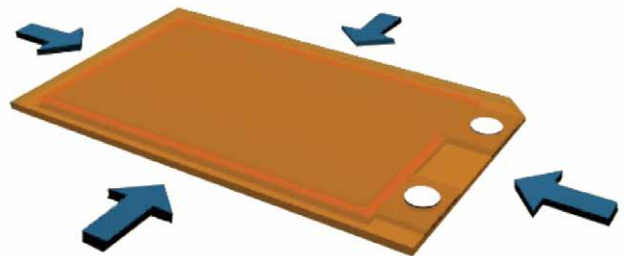

When a voltage is applied, the DuraAct patch transducer contracts laterally

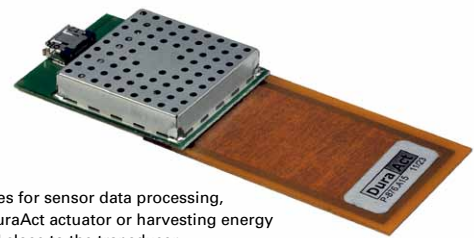

Electronic modules for sensor data processing, controlling the DuraAct actuator or harvesting energy can be connected close to the transducer

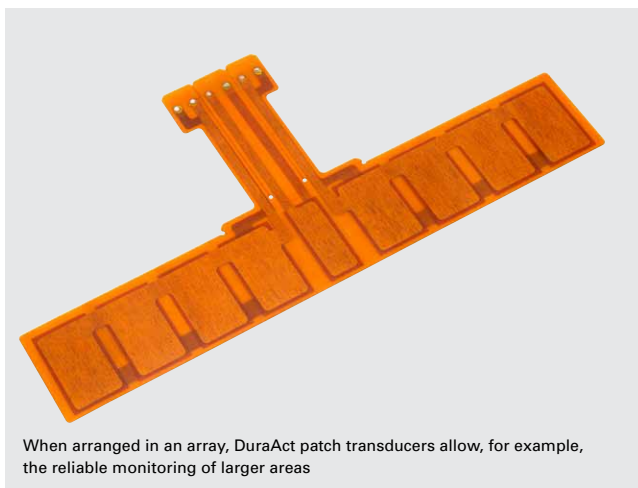

When arranged in an array, DuraAct patch transducers allow, for example, the reliable monitoring of larger areas

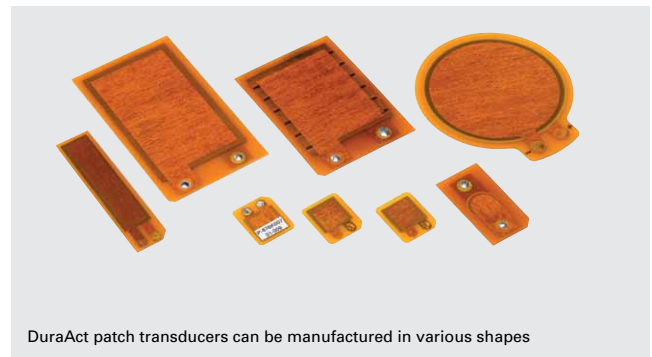

DuraAct patch transducers can be manufactured in various shapes

# Electronic Module for Energy Harvesting

USING PIEZO ACTUATORS FOR ENERGY GENERATION

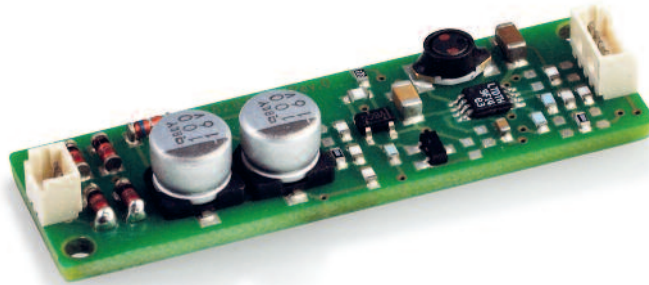

## E-821

- Constant output voltage
- Usable energy 8.7 mJ
- Uses pulsed or continuous excitation
- Adaptation to customer application on request

### OEM electronic module for energy harvesting

For generating energy from vibration. Use in combination with DuraAct patch transducers. Adjustable output voltage. Processes input currents between 20  $\mu$ A and 40 mA, voltage peaks are limited to 15 V. Custom version for operation with piezo stack actuators on request

### Fields of application

Autonomous power supplies, e.g. for wireless sensor networks

### Related Products

P-876 DuraAct Patch Transducers  
P-882 – P-888 PICMA® Stack Multilayer Piezo Actuators



The E-821 energy harvesting electronics is designed to work best with P-876 DuraAct patch transducers

E-821.00	
Function	Electronic module for energy harvesting
Channels	1
Min. input current	20 $\mu$ A
Max. input current	40 mA
Max. continuous input power	500 mW
Output voltage	3.3 V (adjustable from 1.8 to 5.0 V)
Output power (80 ms)	100 mW
Usable energy at the output (200 $\mu$ F)	8.7 mJ
<b>Interface and operation</b>	
Piezo element (voltage input)	2-pin connector
Voltage output	4-pin connector
<b>Miscellaneous</b>	
Operating temperature range	0 to 50°C
Dimensions	48 x 15 x 7 mm
Mass	3.5 g
Material	SMD board
Typ. current consumption	15 $\mu$ A during charging
Typ. power consumption	30% of the converted power

Ask about custom designs!  
 Not authorized for use in the USA and not available in the USA.

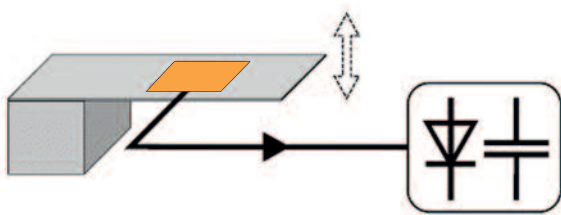

To dimension an energy harvesting system correctly, all important boundary conditions must be known and taken into account. The principle itself is simple: Ambient vibrations produce a charge separation in the piezoceramic DuraAct transducer. The electronic circuitry in the E-821 module then ensures a sufficiently stable output voltage that can be adjusted to the load.

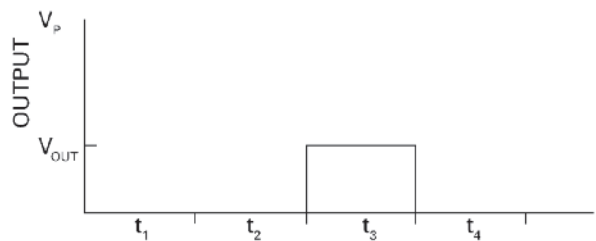
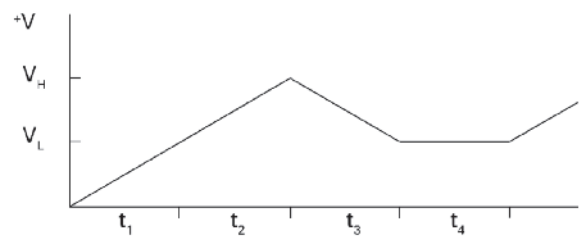

Energy can only be released when the threshold voltage level  $V_H$  has been reached. A constant voltage is available at the output

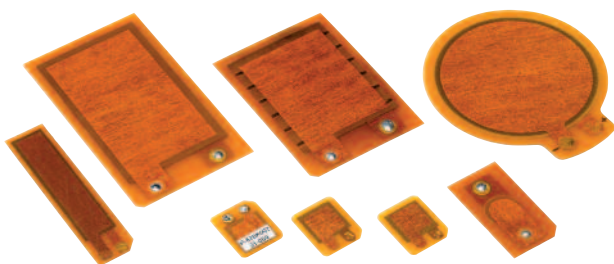

DuraAct patch transducers, which are available in many different designs, can be adapted to the application

WHITEPAPER

# Energy Harvesting Uses the Piezo Effect

DURAACT PIEZO TRANSDUCER PLUS MATCHING ELECTRONICS



Introduction	3
Energy Generation with the Piezo Effect	3
A Complex System	4
Typical Applications for Piezo Energy Harvesting	4
Highly Versatile and Durable Patch Transducers	4
Power Output as a Function of Load Resistance	5
Power Output as a Function of the Excitation Conditions	6
Matching Electronics	6
Conclusion	7
Author	7
Company Profile	8
Contact	8

## Introduction

The term Energy Harvesting is popularly used when electricity is generated from sources such as ambient temperature, vibrations or air flows. Since there are now electronic circuits whose power requirement is of the order of milliwatts, even though its energy yield is relatively low, energy harvesting with piezo-based solutions is always of great interest in situations where electricity cannot be supplied via power cables and one wants to avoid batteries and the maintenance effort required.

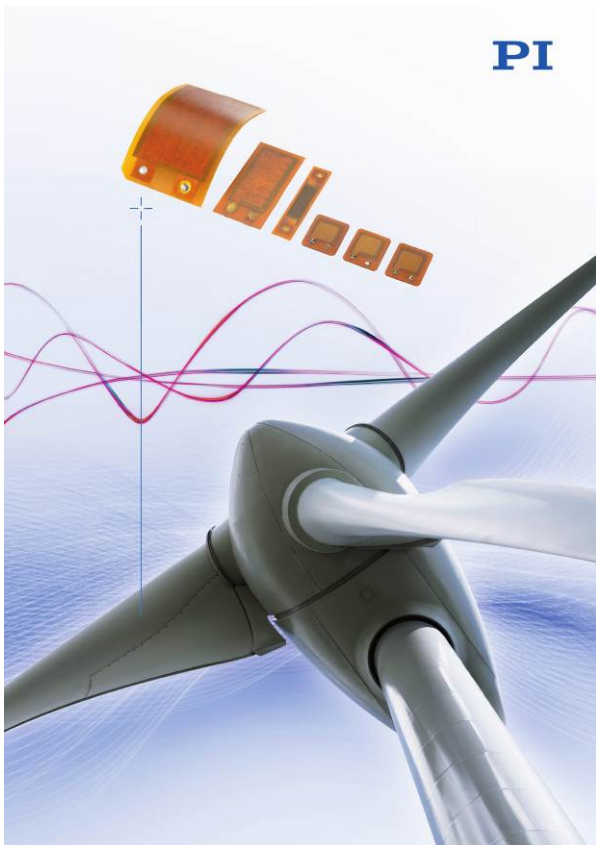

Fig. 1 Energy harvesting, also known as power harvesting or energy scavenging can be based on a number of physical effects. Piezoelectric crystals are also ideal here, for example (Physik Instrumente (PI))

Energy harvesting (Fig. 1) can be based on a number of physical effects. Photovoltaic cells are one option, as are thermoelectric generators which generate electrical energy from temperature gradients.

It is also possible to receive and energetically use the energy from radio waves via antennas, as is the case

with passive RFID tags, for example. Piezoelectric crystals are also ideal for energy harvesting. They generate an electric voltage when force is applied in the form of pressure or vibrations, i.e. they use the kinetic energy available in their environment.

## Energy Generation with the Piezo Effect

When a piezo crystal mechanically deforms as a result of a force applied with tension or pressure, charges are generated which can be measured as a voltage on the electrodes of the piezo element (Fig. 2), a phenomenon known as the direct piezo effect.

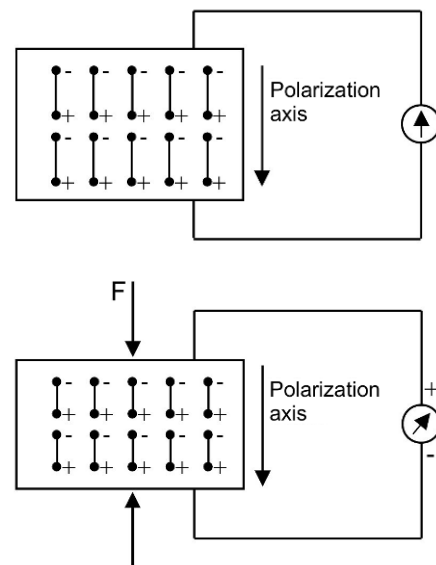

Fig. 2 Energy generation using the piezo effect (Physik Instrumente (PI))

This method of charge generation is familiar from gas ignition systems to generate the ignition voltage, for example. The charge generated (Q) can be described by the mathematical expression below:

$$Q = d \cdot \Delta F$$

The charge constant d (ratio of charge generated to force applied) in this equation is a material-specific constant of the order of 10-10 C/N.

It therefore quickly becomes apparent that the quantity of charge generated is relatively low. This aspect places high demands on mechanical systems and electronics in order to “harvest” the optimum amount of energy.

## A Complex System

A universal energy harvesting solution does not exist, because the energy excitation conditions differ from application to application. Figure 3 shows the construction in principle.

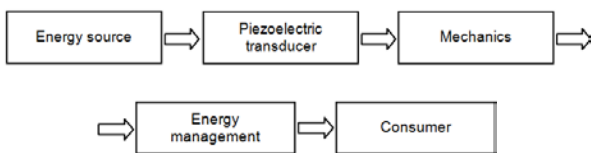

Fig. 3 Design of an energy harvesting system (Physik Instrumente (PI))

To dimension such a system correctly, all important boundary conditions must be known and taken into account. Take the energy source, for example:

One needs to distinguish between continuous and pulsed motions. The requirements of the electric load must also be taken into consideration, of course: The important parameters here include the voltage required, the power and the input impedance, i.e. capacitive or resistive.

It is then possible to use this data to design and dimension the transducer including the mechanical system. Here, PI Ceramic can contribute its years of experience and comprehensive know-how in the design of custom-engineered solutions, which benefit very different sectors of industry.

## Typical Applications for Piezo Energy Harvesting

There are many applications where the energy generated by energy harvesting from the environment is sufficient and can be used in a worthwhile way.

Although small button cells have quite long useful lives nowadays, it may make sense to avoid batteries nevertheless, because it is too much effort to test and change them when the load is installed in a location which is inaccessible or difficult to reach. Energy harvesting solutions can then be the means of choice, despite their complexity. A typical example for this is so-called health monitoring on the rotor blades of wind turbines.

Further interesting fields for energy harvesting are data monitoring and transmission in heating and air conditioning technology. If vehicle vibrations are used for energy generation, products can be continuously monitored during transport without the corresponding sensors having to be connected up or equipped with batteries. This is useful if temperatures have to be recorded inside closed containers, for example. Rain sensors can be powered via energy harvesting in the windscreens of vehicles, and the energy requirements of wireless ZigBee networks can also often be covered by “harvesting” energy in the environment.

## Highly Versatile and Durable Patch Transducers

In principle, every piezoceramic component or every piezo actuator can be used for energy harvesting. By converting mechanical vibrations of a few kilohertz into electric voltage, a few milliwatts of power can be generated, and this can be supplied to electrical components, e.g. processors, sensors or mini-transmitters.

	P-867.A11	P-867.A12	P-867.A15	Tolerance
Length	61 mm	61 mm	61 mm	± 0.5 mm
Width	35 mm	35 mm	35 mm	± 0.5 mm
Thickness	0.4 mm	0.5 mm	0.8 mm	± 0.5 mm
Bending radius	12 mm	20 mm	70 mm	max.
Thickness of the ceramic	100 µm	200 µm	500 µm	
Electrical capacitance	150 nF	90 nF	45 nF	± 20 %
Operating temperature range	-20 to +150 °C	-20 to +150 °C	-20 to +150 °C	
Mass	2.1 g	3.5 g	7.2 g	± 5 %
Voltage connection	Soldering points	Soldering points	Soldering points	

Fig. 4 The table shows the technical data of different piezo transducers (Physik Instrumente (PI))

A particularly practical solution is the durable, laminated DuraAct transducer which PI Ceramic provides in a wide range of standard designs (Fig. 4 and Fig. 5).

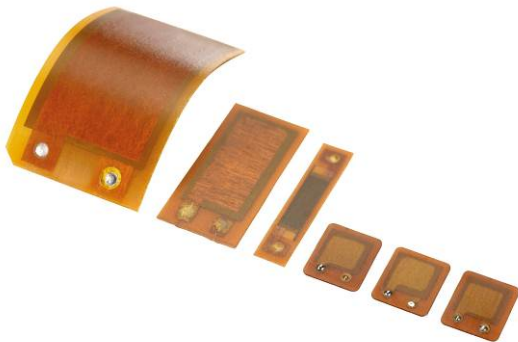

Fig. 5 Highly versatile and durable patch transducers (Physik Instrumente (PI))

A DuraAct patch transducer consists of piezoceramic plates or films which are embedded in a polymer together with their contacts. This mechanically preloads the brittle ceramic while electrically insulating it at the same time. The mechanical preloading extends the loading limits of the ceramic so it can also be applied to curved surfaces, for example. At the same time the compact design including the insulation makes it easier for the user to handle; it is even possible to embed the patch transducer in a composite material.

The patch transducers ideally have a symmetrical structure, i.e. when the transducer is bent, the same quantity of charge with opposite sign is generated on both electrode surfaces; it would not be possible to measure a potential difference. This makes it necessary to bond the transducer onto a substrate (e.g. aluminum, CRP or GRP material), thus producing the conventional bender structure. Charges can now be generated by fixing the bender at the edge and displacing it, the charges being proportional to the stresses or strains introduced into the ceramic to a first approximation.

A test provides information on how the thickness of the ceramic affects the energy harvesting characteristics. To this end, the DuraAct transducers were bonded to CRP strips and fixed on one edge. A rotating eccentric disk displaces the bender transducer.

With this set-up it was thus possible to realize the reproducible fixing and excitation conditions necessary for the direct comparison of transducers (variation of frequency and displacement).

## Power Output as a Function of Load Resistance

Moreover, it is possible to compare how the CRP bender structures and the various DuraAct transducers (P-876.A11, -A12 and -A15) bonded on CRP behave at different load resistances and the same excitation conditions (frequency: 1 Hz, displacement: 5 mm). The AC voltage from the generator was rectified by a Graetz full wave bridge rectifier and smoothed with a capacitor (10  $\mu$ F). The power output was then determined for every type of DuraAct at different load impedances.

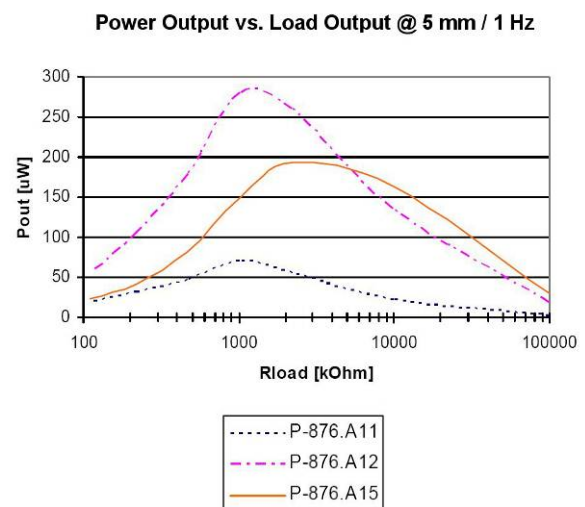

Fig. 6 Power output as a function of the load resistance (Physik Instrumente (PI))

This showed that every transducer in the test had a different electrical load range with optimum power output (Fig. 6). The bender structure with the DuraAct P-876.A12 provides the greatest power output under the boundary conditions stated. This demonstrates very well that optimum power output always requires an optimized transducer design with corresponding power adjustment.

## Power Output as a Function of the Excitation Conditions

The other results of the investigation are restricted to the bender structure with the DuraAct P 876.A12 patch transducer.

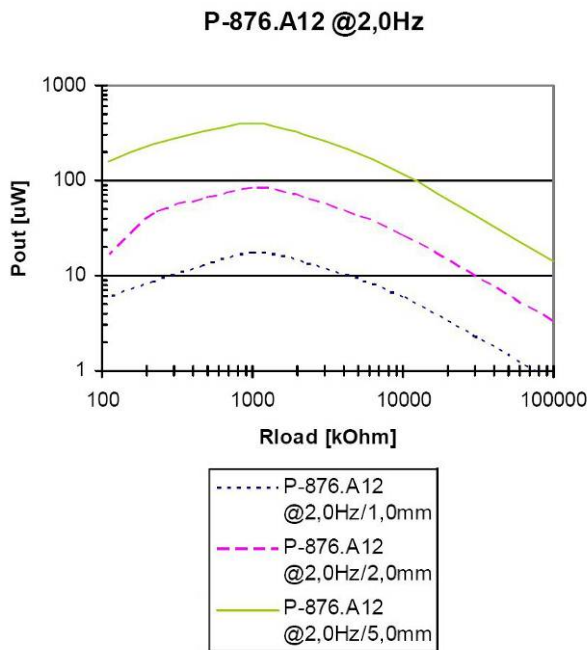

Fig. 7 Power output as a function of the excitation conditions (Physik Instrumente (PI))

Figure 7 shows the power output as a function of the displacement. The power output is crucially determined by the mechanical deformation of the bender structure. The larger the displacement, the greater the charge and power generated. It is therefore particularly important to analyze the energy sources available and to develop a mechanical design adapted to them which allows optimum conversion of mechanical energy into electrical.

The frequency of the excitation also has a direct effect on the power output. As Figure 8 shows, there is an almost linear relationship between power output and excitation frequency. It is also possible to see a shift of the optimum load range to smaller values at higher excitation frequency.

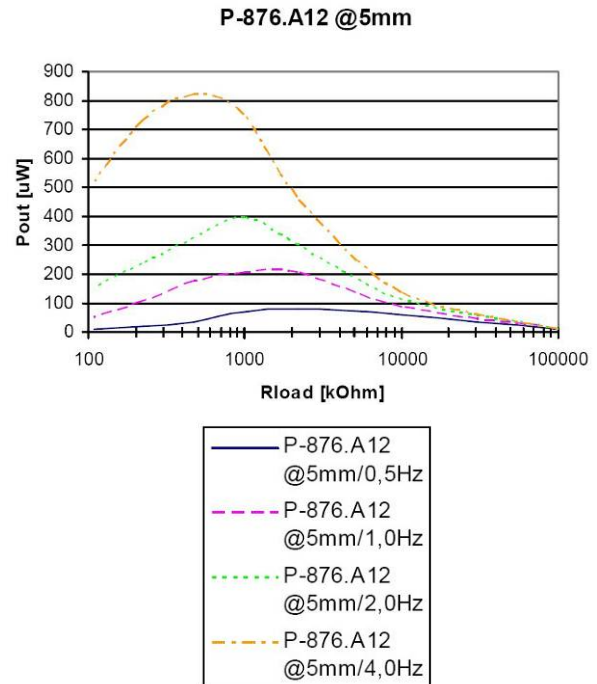

Fig. 8 The relationship between power output and excitation frequency is almost linear (Physik Instrumente (PI))

## Matching Electronics

The test electronics available for piezo energy harvesting include a rectifier with downstream storage capacitor and load switch. They can process alternating and continuous input voltages. The electronic circuit decouples the load (i.e. the consumer) from the generator and the energy can be collected and stored over a long period.

For the charging process of the storage capacitor the open-circuit voltage of the generator must be higher than  $V_{High}$ .

When the voltage level  $V_H$  is reached after a charging time  $t_1+t_2$  the discharge process (supply to a load,  $t_3$ ) begins. If the voltage available decreases to the value  $V_{Low}$ , no further power output is possible, the storage capacitor must be charged up again (Fig. 9).

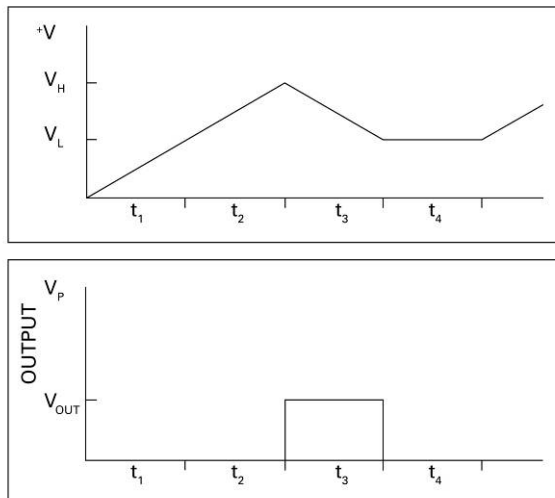

Fig. 9 Energy is only supplied between the voltage levels  $V_H$  and  $V_L$  (Physik instrumente (PI))

Energy can therefore only be supplied between the voltage levels  $V_H$  and  $V_L$ :

$$W_{el} = \frac{C}{2} (V_H - V_L)^2$$

If one varies the capacitor, it is possible to match the electronics to the power requirement of the load. The output voltage of the test electronics can be flexibly adjusted between 1.8 and 5 V. Due to the repeating phases of “charging” (w), “storing”, “energy output”, “charging” this solution is particularly suitable for applications which do not have a continuous power requirement, e.g. in wireless sensor networks where the charge is generated and stored in measurement breaks and the energy is retrieved for the measurement and data transmission.

If the piezo transducer, the mechanical system and the electronics are matched to each other so as to take account of the application-specific boundary conditions, piezo-based energy harvesting can be a practical way of supplying energy in many other applications as well.

## Conclusion

The results here show as an example how ambient energy can be converted to electrical energy and then be used to supply a corresponding consumer under specific conditions.

There is no general energy harvesting solution that serves all purposes. The design of the piezoelectric transducer, the electronics and the kind of excitation used substantially determine the outcome and need to be matched individually for a certain task.

More information on DuraAct piezoelectric patch transducers is available at:

[www.piceramic.com](http://www.piceramic.com)

## Author

Dipl.-Phys. Birgit Schulze, Product Manager, Physik Instrumente (PI) GmbH & Co. KG.

## Company Profile

PI Ceramic from Lederhose/Germany is a subsidiary of PI (Physik Instrumente in Karlsruhe) and one of the world's leading players in the field of actuator and sensoric piezo products.

PI Ceramic currently employs over 150 staff, including no less than 30 engineers, in piezo research, development and manufacture. A broad range of expertise in the complex development and manufacturing process of functional ceramic components combined with state of the art equipment ensure high quality, flexibility and adherence to supply deadlines.

The company supplies piezoceramic solutions for all important high-tech markets from industrial automation and the semiconductor industry, medical engineering, mechanical engineering and high-precision engineering through to the aeronautics industry and the automotive sector.

## Contact

PI Ceramic GmbH

Lindenstrasse

07589 Lederhose

Phone +49 36 604 / 882 – 0

Fax +49 36 604 / 882 – 4249

Mailto: [info@piceramic.de](mailto:info@piceramic.de)

<http://www.piceramic.de/>

Physik Instrumente (PI) GmbH & Co. KG

Auf der Römerstraße 1

76228 Karlsruhe

Phone +49 721 / 48 46 – 0

Fax +49 721 / 48 46 – 1019

Mailto: [info@pi.ws](mailto:info@pi.ws)

<http://www.pi.ws>

## Headquarters

### GERMANY

**Physik Instrumente (PI)  
GmbH & Co. KG**  
Auf der Roemerstr. 1  
76228 Karlsruhe/Palmbach  
Tel. +49 (721) 4846-0  
Fax +49 (721) 4846-1019  
info@pi.ws  
www.pi.ws

**PI miCos GmbH**  
Eschbach  
info@pimicos.de  
www.pimicos.de

**PI Ceramic GmbH**  
Lederhose  
info@piceramic.de  
www.piceramic.de

## Subsidiaries

### USA (East) & CANADA

**PI (Physik Instrumente) L.P.**  
16 Albert St.  
Auburn, MA 01501  
Tel. +1 (508) 832 3456  
Fax +1 (508) 832 0506  
info@pi-usa.us  
www.pi-usa.us

### USA (West) & MEXICO

**PI (Physik Instrumente) L.P.**  
5420 Trabuco Rd., Suite 100  
Irvine, CA 92620  
Tel. +1 (949) 679 9191  
Fax +1 (949) 679 9292  
info@pi-usa.us  
www.pi-usa.us

### JAPAN

**PI Japan Co., Ltd.**  
Tachikawa  
Business Center Bldg. 5F  
2-38-5 Akebono-cho  
Tachikawa-shi, Tokyo 190-0012  
Tel. +81 (42) 526 7300  
Fax +81 (42) 526 7301  
info@pi-japan.jp  
www.pi-japan.jp

**PI Japan Co., Ltd.**  
Hanahara Daini Bldg. #703  
4-11-27 Nishinakajima  
Yodogawa-ku, Osaka-shi  
Osaka 532-0011  
Tel. +81 (6) 6304 5605  
Fax +81 (6) 6304 5606  
info@pi-japan.jp  
www.pi-japan.jp

### UK & IRELAND

**PI (Physik Instrumente) Ltd.**  
Trent House, University Way,  
Cranfield Technology Park,  
Cranfield, Bedford MK43 0AN  
Tel. +44 (1234) 756 360  
Fax +44 (1234) 756 369  
uk@pi.ws  
www.physikinstrumente.co.uk

### ITALY

**Physik Instrumente (PI) S. r. l.**  
Via G. Marconi, 28  
20091 Bresso (MI)  
Tel. +39 (02) 665 011 01  
Fax +39 (02) 610 396 56  
info@pionline.it  
www.pionline.it

### FRANCE

**PI France S.A.S.**  
244 bis, avenue Marx Dormoy  
92120 Montrouge  
Tel. +33 (1) 55 22 60 00  
Fax +33 (1) 41 48 56 62  
info.france@pi.ws  
www.pifrance.fr

### CHINA

**Physik Instrumente  
(PI Shanghai) Co., Ltd.**  
Building No. 7-106  
Longdong Avenue 3000  
201203 Shanghai, China  
Tel. +86 (21) 518 792 98  
Fax +86 (21) 687 900 98  
info@pi-china.cn  
www.pi-china.cn

### SOUTH EAST ASIA

**PI (Physik Instrumente)  
Singapore LLP**  
20 Sin Ming Lane  
#05-60 Midview City  
Singapore 573968  
Tel. +65 665 98400  
Fax +65 665 98404  
info-sg@pi.ws  
www.pi-singapore.sg  
For ID / MY / PH / SG / TH

### KOREA

**PI Korea Ltd.**  
6F Jeongu Bldg.  
Cheonho-Daero 1111  
Gangdong-gu  
138-814 Seoul  
Tel. +82 2475 0060  
Fax +82 2475 3663  
info-kr@pi.ws  
www.pi-korea.ws