

## PZ138E P-0xx Piezo Actuator User Manual

Version: 1.2.0

Date: 10.12.2014



### This document describes the following products:

- **P-007 - P-056**  
PICA Stack piezo actuators  
travel range to 300  $\mu\text{m}$
- **P-010.xxP - P-056.xxP**  
PICA Power piezo actuators  
travel range to 180  $\mu\text{m}$
- **P-010.xxH - P-025.xxH**  
PICA Thru ring actuators  
travel range to 80  $\mu\text{m}$

(x stands for the different models.)

### This document also applies to custom products of the following product lines:

- PICA Stack
- PICA Power
- PICA Thru

(product line see delivery note)



Physik Instrumente (PI) GmbH & Co. KG is the owner of the following trademarks:  
PI®, PIC®, PICMA®, PLine®, PIFOC®, PiezoWalk®, NEXACT®, NEXLINE®,  
NanoCube®, NanoAutomation®, Picoactuator®, PInano®

© 2014 PI Ceramic GmbH, Lederhose, Germany. The text, photographs and drawings in this manual are protected by copyright. With regard thereto, PI Ceramic GmbH retains all the rights. Use of said text, photographs and drawings is permitted only in part and only upon citation of the source.

Original instructions

First printing: 10.12.2014

Document number: PZ138E, CBo, Version 1.2.0

Subject to change without notice. This manual is superseded by any new release. The latest release is available for download (p. 3) on our website.



# Contents

|          |  |           |
|----------|--|-----------|
| <b>1</b> | <b>About this Document</b>                                 | <b>1</b>  |
| 1.1      | Goal and Target Audience of this User Manual .....         | 1         |
| 1.2      | Validity for Custom Products .....                         | 1         |
| 1.3      | Symbols and Typographic Conventions .....                  | 1         |
| 1.4      | Figures .....  | 2         |
| 1.5      | Other Applicable Documents .....                           | 3         |
| 1.6      | Downloading Manuals .....                                  | 3         |
| <b>2</b> | <b>Safety</b>  | <b>5</b>  |
| 2.1      | Intended Use .....   | 5         |
| 2.2      | General Safety Instructions .....                          | 6         |
| 2.3      | Organizational Measures .....                              | 7         |
| <b>3</b> | <b>Product Description</b>                                 | <b>9</b>  |
| 3.1      | Model Overview .....                                       | 9         |
| 3.2      | Product View .....   | 13        |
| 3.3      | Product Labeling .....                                     | 14        |
| 3.4      | Scope of Delivery .....                                    | 15        |
| 3.5      | Suitable Electronics .....                                 | 15        |
| 3.6      | Accessories .....  | 16        |
| 3.7      | Technical Features .....                                   | 17        |
| <b>4</b> | <b>Unpacking</b>   | <b>19</b> |
| <b>5</b> | <b>Installation</b>  | <b>21</b> |
| 5.1      | General Notes on Installation .....                        | 21        |
| 5.2      | Mounting the P-0xx .....                                   | 26        |
| 5.3      | Applying a Preload .....                                   | 27        |
| 5.4      | Applying the Load .....                                    | 28        |
| 5.5      | Connecting the P-0xx to the Electronics .....              | 29        |
| 5.6      | Connecting the Temperature Sensor to the Electronics ..... | 32        |

|        |  |    |
|--------|--|----|
| 6      | Start-Up and Operation   | 35 |
| 6.1    | General Notes on Start-Up and Operation                                  | 35 |
| 6.2    | Determining the Operating Parameters                                     | 40 |
| 6.2.1  | Overview of Limiting Factors   | 41 |
| 6.2.2  | Calculating the Effective Mass   | 42 |
| 6.2.3  | Calculating the Maximum Operating Frequency of the Loaded Piezo Actuator | 42 |
| 6.2.4  | Calculating the Forces that Occur During Dynamic Operation               | 43 |
| 6.2.5  | Calculating the Power Requirement for Sinusoidal Operation               | 44 |
| 6.3    | Operating the P-0xx  | 45 |
| 6.4    | Discharging the P-0xx  | 45 |
| 6.5    | Short-Circuiting the P-0xx   | 47 |
| 7      | Maintenance  | 49 |
| 7.1    | General Notes on Maintenance   | 49 |
| 7.2    | Cleaning the P-0xx   | 49 |
| 8      | Troubleshooting  | 51 |
| 9      | Customer Service   | 53 |
| 10     | Technical Data   | 55 |
| 10.1   | Specifications   | 55 |
| 10.1.1 | Data Table   | 55 |
| 10.1.2 | Maximum Ratings  | 58 |
| 10.1.3 | Compressive/Tensile Stress Capacity and Preload                          | 60 |
| 10.1.4 | Ambient Conditions and Classifications                                   | 61 |
| 10.2   | Dimensions   | 62 |
| 11     | Old Equipment Disposal   | 63 |
| 12     | EC Declaration of Conformity   | 65 |

# 1 About this Document

## In this Chapter

|  |   |
|--|---|
| Goal and Target Audience of this User Manual ..... | 1 |
| Symbols and Typographic Conventions .....          | 1 |
| Figures .....                                      | 2 |
| Other Applicable Documents .....                   | 3 |
| Downloading Manuals .....                          | 3 |

## 1.1 Goal and Target Audience of this User Manual

This user manual contains the necessary information for the intended use of the P-0xx (x stands for the different models, p. 9).

Basic knowledge of drive technologies and suitable safety measures is assumed.

The latest versions of the user manuals are available for download (p. 3) on our website.

## 1.2 Validity for Custom Products

This user manual also applies to custom products of the PICA Stack, PICA Power and PICA Thru product lines, except where superseded by the accompanying documentation of these products.

The product line is stated on the delivery note of the custom product.

The properties of custom products may differ from those stated in this manual.

## 1.3 Symbols and Typographic Conventions

The following symbols and typographic conventions are used in this user manual:

### **DANGER**



#### **Imminently hazardous situation**

If not avoided, the hazardous situation will result in death or serious injury.

- Actions to take to avoid the situation.

**CAUTION****Dangerous situation**

If not avoided, the dangerous situation will result in minor injury.

- Actions to take to avoid the situation.

**NOTICE****Dangerous situation**

If not avoided, the dangerous situation will result in damage to the equipment.

- Actions to take to avoid the situation.

**INFORMATION**

Information for easier handling, tricks, tips, etc.

| <b>Symbol</b> | <b>Meaning</b>  |
|---------------|---|
| 1.            | Action consisting of several steps whose sequential order must be observed                |
| 2.            |   |
| ➤             | Action consisting of one or several steps whose sequential order is irrelevant            |
| ▪             | List item   |
| p. 5          | Cross-reference to page 5   |
| <b>RS-232</b> | Labeling of an operating element on the product (example: socket of the RS-232 interface) |

## 1.4 Figures

For better understandability, the colors, proportions and degree of detail in illustrations can deviate from the actual circumstances. Photographic illustrations may also differ and must not be seen as guaranteed properties.

## 1.5 Other Applicable Documents

The devices and software tools which are mentioned in this documentation are described in their own manuals.

The latest versions of the user manuals are available for download (p. 3) on our website.

| Product   | Document           |
|---|--------------------|
| E-421.00 High-Power Piezo Amplifier Module                        | PZ178E User Manual |
| E-470.20 high-power piezo amplifier                               | PZ178E User Manual |
| E-471.20 high-power piezo amplifier                               | PZ178E User Manual |
| E-472.20 high-power piezo amplifier, 2 channels                   | PZ178E User Manual |
| E-462.00 HVPZT piezo amplifier                                    | PZ210E User Manual |
| E-462.OE1 HVPZT piezo amplifier module, 10 to 1000 V, OEM version | PZ210E User Manual |
| E-464.00 HVPZT piezo amplifier, 3 channels                        | PZ176E User Manual |
| E-481.00 high-power piezo amplifier / controller                  | PZ170E User Manual |
| E-482.00 PICA high-power piezo amplifier / controller             | PZ236E User Manual |
| E-500 modular piezo controller                                    | PZ62E User Manual  |

## 1.6 Downloading Manuals

### **INFORMATION**

If a manual is missing or problems occur with downloading:

- Contact our customer service department (p. 53).

### **INFORMATION**

For some products (e.g. Hexapod systems and electronics that are delivered with a CD), access to the manuals is password-protected. The password is stored on the CD. Availability of the manuals:

- Password-protected manuals: FTP download directory
  - Freely available manuals: PI website
  - Follow the corresponding instructions for downloading.
- 

### **Download freely accessible manuals**

1. Open the website <http://www.pi-portal.ws>.
2. Click **Downloads**.
3. Click the corresponding product category.
4. Go to the corresponding product code.  
The available manuals are displayed.
5. Click the desired manual and save it on the hard disk of your PC or on a data storage medium.

### **Download password-protected manuals**

1. Insert the product CD in the PC drive.
2. Switch to the Manuals directory on the CD.
3. In the Manuals directory, open the Release News (file including **releasenews** in the file name).
4. Find the user name and the password in the section "User login for software download" in the Release News.
5. Open the FTP download directory (<ftp://pi-ftp.ws>).
  - Windows operating systems: Open the FTP download directory in Windows Explorer.
6. Log in with the user name and the password from the Release News.
7. In the directory of the corresponding product, go to the Manuals sub-directory.
8. Copy the desired manual to the hard disk of your PC or to a data storage medium.



## 2 Safety

### In this Chapter

|                                   |   |
|-----------------------------------|---|
| Intended Use .....                | 5 |
| General Safety Instructions ..... | 6 |
| Organizational Measures.....      | 7 |

### 2.1 Intended Use

The P-0xx is intended to be used in an environment which is free of dirt, oil, and lubricants.

In accordance with its design, the P-0xx is intended for integration into a mechanical system and for the following applications:

- Positioning of loads
- Dynamic positioning
- Vibration damping
- Force generation

The operator is responsible for a standards compliant integration of the P-0xx into the overall system.

The motion of the P-0xx takes place in one axis. When mounting the actuator without applying a preload, observe the maximum tensile stress capacity (p. 60).

For operation of the P-0xx, suitable electronics that provides the required operating voltages is required. The electronics is not included in the scope of delivery of the P-0xx. We recommend the use of suitable electronics (p. 15) from PI.

## 2.2 General Safety Instructions

The P-0xx is built according to state-of-the-art technology and recognized safety standards. Improper use can result in personal injury and/or damage to the P-0xx.

- Only use the P-0xx for its intended purpose, and only use it if it is in a good working order.
- Read the user manual.
- Immediately eliminate any faults and malfunctions that are likely to affect safety.

The operator is responsible for the correct installation and operation of the P-0xx.

Temperature changes and compressive stresses can induce charges in the P-0xx piezo actuator. After being disconnected from the electronics, the piezo actuator can stay charged for several hours. Touching the live parts of the P-0xx can result in serious injury or death from electric shock.

- Do **not** touch the P-0xx unless it is discharged (p. 45).
- When handling the piezo actuator, wear powder-free nitrile or latex gloves and suitable protective goggles.
- Keep the piezo actuator short-circuited (p. 47) when it is not connected to the electronics.
- Do **not** disassemble the piezo actuator.

The system into which the P-0xx is integrated (e.g. case or surrounding mechanical system) must be connected to a protective earth conductor. If the protective earth conductor is missing or not properly connected, dangerous touch voltages can occur on the overall system in case of malfunction or failure of the system. If touch voltages exist, touching the overall system can result in serious injury or death from electric shock.

- Before start-up, connect the overall system to a protective earth conductor in accordance with the applicable standards.
- Do **not** remove the protective earth conductor during operation.
- If the protective earth conductor has to be temporarily removed (e.g. for modifications), reconnect the overall system to the protective earth conductor before starting it up again.

During operation, the P-0xx carries voltages of up to 1000 V. The shrink tubing of the piezo actuator and protective polymer layer beneath do **not** provide contact protection against electric shock. Touching the live parts of the P-0xx can result in serious injury or death from electric shock.

- Do **not** touch the piezo actuator during operation.
- Electrically insulate the piezo actuator from the surrounding mechanical system to prevent direct or indirect contact with live parts. Observe the clearances and creepage distances required for the operating voltage, and observe the standards applicable to your application.

Mechanical forces can damage or misalign the P-0xx.

- Avoid impacts that affect the P-0xx.
- Do **not** drop the P-0xx.
- Avoid torques, bending forces and lateral forces on the P-0xx.
- Do **not** use metal tools during installation.
- Do **not** exceed the maximum permissible stress and load capacities according to the specifications (p. 55).

## 2.3 Organizational Measures

### User manual

- Always keep this user manual available by the P-0xx.  
The latest versions of the user manuals are available for download (p. 3) on our website.
- Add all information given by the manufacturer to the user manual, for example supplements or Technical Notes.
- If you pass the P-0xx on to other users, also turn over this user manual as well as all other relevant information provided by the manufacturer.
- Only use the device on the basis of the complete user manual. If your user manual is incomplete and is therefore missing important information, serious or fatal injury as well as property damage can result.
- Only install and operate the P-0xx after having read and understood this user manual.

### **Personnel qualification**

Only authorized and qualified personnel must install, operate, maintain and clean the P-0xx.

## 3 Product Description

### In this Chapter

|                            |    |
|----------------------------|----|
| Model Overview .....       | 9  |
| Product View .....         | 13 |
| Product Labeling.....      | 14 |
| Scope of Delivery .....    | 15 |
| Suitable Electronics ..... | 15 |
| Accessories .....          | 16 |
| Technical Features .....   | 17 |

### 3.1 Model Overview

#### PICA Stack piezo actuators

| Model    | Description  |
|----------|--|
| P-007.00 | PICA Stack piezo actuator, 5 $\mu$ m travel range, OD 7 mm x L 8 mm      |
| P-007.10 | PICA Stack piezo actuator, 15 $\mu$ m travel range, OD 7 mm x L 17 mm    |
| P-007.20 | PICA Stack piezo actuator, 30 $\mu$ m travel range, OD 7 mm x L 29 mm    |
| P-007.40 | PICA Stack piezo actuator, 60 $\mu$ m travel range, OD 7 mm x L 54 mm    |
| P-010.00 | PICA Stack piezo actuator, 5 $\mu$ m travel range, OD 10 mm x L 8 mm     |
| P-010.10 | PICA Stack piezo actuator, 15 $\mu$ m travel range, OD 10 mm x L 17 mm   |
| P-010.20 | PICA Stack piezo actuator, 30 $\mu$ m travel range, OD 10 mm x L 30 mm   |
| P-010.40 | PICA Stack piezo actuator, 60 $\mu$ m travel range, OD 10 mm x L 56 mm   |
| P-010.80 | PICA Stack piezo actuator, 120 $\mu$ m travel range, OD 10 mm x L 107 mm |
| P-016.10 | PICA Stack piezo actuator, 15 $\mu$ m travel range, OD 16 mm x L 17 mm   |
| P-016.20 | PICA Stack piezo actuator, 30 $\mu$ m travel range, OD 16 mm x L 29 mm   |
| P-016.40 | PICA Stack piezo actuator, 60 $\mu$ m travel range, OD 16 mm x L 54 mm   |
| P-016.80 | PICA Stack piezo actuator, 120 $\mu$ m travel range, OD 16 mm x L 101 mm |
| P-016.90 | PICA Stack piezo actuator, 180 $\mu$ m travel range, OD 16 mm x L 150 mm |
| P-025.10 | PICA Stack piezo actuator, 15 $\mu$ m travel range, OD 25 mm x L 18 mm   |
| P-025.20 | PICA Stack piezo actuator, 30 $\mu$ m travel range, OD 25 mm x L 30 mm   |

| Model     | Description   |
|-----------|---|
| P-025.40  | PICA Stack piezo actuator, 60 $\mu\text{m}$ travel range, OD 25 mm $\times$ L 53 mm   |
| P-025.80  | PICA Stack piezo actuator, 120 $\mu\text{m}$ travel range, OD 25 mm $\times$ L 101 mm |
| P-025.90  | PICA Stack piezo actuator, 180 $\mu\text{m}$ travel range, OD 25 mm $\times$ L 149 mm |
| P-025.150 | PICA Stack piezo actuator, 250 $\mu\text{m}$ travel range, OD 25 mm $\times$ L 204 mm |
| P-025.200 | PICA Stack piezo actuator, 300 $\mu\text{m}$ travel range, OD 25 mm $\times$ L 244 mm |
| P-035.10  | PICA Stack piezo actuator, 15 $\mu\text{m}$ travel range, OD 35 mm $\times$ L 20 mm   |
| P-035.20  | PICA Stack piezo actuator, 30 $\mu\text{m}$ travel range, OD 35 mm $\times$ L 32 mm   |
| P-035.40  | PICA Stack piezo actuator, 60 $\mu\text{m}$ travel range, OD 35 mm $\times$ L 57 mm   |
| P-035.80  | PICA Stack piezo actuator, 120 $\mu\text{m}$ travel range, OD 35 mm $\times$ L 104 mm |
| P-035.90  | PICA Stack piezo actuator, 180 $\mu\text{m}$ travel range, OD 35 mm $\times$ L 153 mm |
| P-045.20  | PICA Stack piezo actuator, 30 $\mu\text{m}$ travel range, OD 45 mm $\times$ L 33 mm   |
| P-045.40  | PICA Stack piezo actuator, 60 $\mu\text{m}$ travel range, OD 45 mm $\times$ L 58 mm   |
| P-045.80  | PICA Stack piezo actuator, 120 $\mu\text{m}$ travel range, OD 45 mm $\times$ L 105 mm |
| P-045.90  | PICA Stack piezo actuator, 180 $\mu\text{m}$ travel range, OD 45 mm $\times$ L 154 mm |
| P-050.20  | PICA Stack piezo actuator, 30 $\mu\text{m}$ travel range, OD 50 mm $\times$ L 33 mm   |
| P-050.40  | PICA Stack piezo actuator, 60 $\mu\text{m}$ travel range, OD 50 mm $\times$ L 58 mm   |
| P-050.80  | PICA Stack piezo actuator, 120 $\mu\text{m}$ travel range, OD 50 mm $\times$ L 105 mm |
| P-050.90  | PICA Stack piezo actuator, 180 $\mu\text{m}$ travel range, OD 50 mm $\times$ L 154 mm |
| P-056.20  | PICA Stack piezo actuator, 30 $\mu\text{m}$ travel range, OD 56 mm $\times$ L 33 mm   |
| P-056.40  | PICA Stack piezo actuator, 60 $\mu\text{m}$ travel range, OD 56 mm $\times$ L 58 mm   |
| P-056.80  | PICA Stack piezo actuator, 120 $\mu\text{m}$ travel range, OD 56 mm $\times$ L 105 mm |
| P-056.90  | PICA Stack piezo actuator, 180 $\mu\text{m}$ travel range, OD 56 mm $\times$ L 154 mm |

**PICA Power piezo actuators**

| Model     | Description   |
|-----------|---|
| P-010.00P | PICA Power piezo actuator, 5 $\mu\text{m}$ travel range, OD 10 mm $\times$ L 9 mm     |
| P-010.10P | PICA Power piezo actuator, 15 $\mu\text{m}$ travel range, OD 10 mm $\times$ L 18 mm   |
| P-010.20P | PICA Power piezo actuator, 30 $\mu\text{m}$ travel range, OD 10 mm $\times$ L 31 mm   |
| P-010.40P | PICA Power piezo actuator, 60 $\mu\text{m}$ travel range, OD 10 mm $\times$ L 58 mm   |
| P-010.80P | PICA Power piezo actuator, 120 $\mu\text{m}$ travel range, OD 10 mm $\times$ L 111 mm |
| P-016.10P | PICA Power piezo actuator, 15 $\mu\text{m}$ travel range, OD 16 mm $\times$ L 18 mm   |
| P-016.20P | PICA Power piezo actuator, 30 $\mu\text{m}$ travel range, OD 16 mm $\times$ L 31 mm   |
| P-016.40P | PICA Power piezo actuator, 60 $\mu\text{m}$ travel range, OD 16 mm $\times$ L 58 mm   |
| P-016.80P | PICA Power piezo actuator, 120 $\mu\text{m}$ travel range, OD 16 mm $\times$ L 111 mm |
| P-016.90P | PICA Power piezo actuator, 180 $\mu\text{m}$ travel range, OD 16 mm $\times$ L 163 mm |
| P-025.10P | PICA Power piezo actuator, 15 $\mu\text{m}$ travel range, OD 25 mm $\times$ L 20 mm   |
| P-025.20P | PICA Power piezo actuator, 30 $\mu\text{m}$ travel range, OD 25 mm $\times$ L 33 mm   |
| P-025.40P | PICA Power piezo actuator, 60 $\mu\text{m}$ travel range, OD 25 mm $\times$ L 60 mm   |
| P-025.80P | PICA Power piezo actuator, 120 $\mu\text{m}$ travel range, OD 25 mm $\times$ L 113 mm |
| P-025.90P | PICA Power piezo actuator, 180 $\mu\text{m}$ travel range, OD 25 mm $\times$ L 165 mm |
| P-035.10P | PICA Power piezo actuator, 15 $\mu\text{m}$ travel range, OD 35 mm $\times$ L 21 mm   |
| P-035.20P | PICA Power piezo actuator, 30 $\mu\text{m}$ travel range, OD 35 mm $\times$ L 34 mm   |
| P-035.40P | PICA Power piezo actuator, 60 $\mu\text{m}$ travel range, OD 35 mm $\times$ L 61 mm   |
| P-035.80P | PICA Power piezo actuator, 120 $\mu\text{m}$ travel range, OD 35 mm $\times$ L 114 mm |
| P-035.90P | PICA Power piezo actuator, 180 $\mu\text{m}$ travel range, OD 35 mm $\times$ L 166 mm |
| P-045.20P | PICA Power piezo actuator, 30 $\mu\text{m}$ travel range, OD 45 mm $\times$ L 36 mm   |
| P-045.40P | PICA Power piezo actuator, 60 $\mu\text{m}$ travel range, OD 45 mm $\times$ L 63 mm   |
| P-045.80P | PICA Power piezo actuator, 120 $\mu\text{m}$ travel range, OD 45 mm $\times$ L 116 mm |
| P-045.90P | PICA Power piezo actuator, 180 $\mu\text{m}$ travel range, OD 45 mm $\times$ L 169 mm |
| P-056.20P | PICA Power piezo actuator, 30 $\mu\text{m}$ travel range, OD 56 mm $\times$ L 36 mm   |
| P-056.40P | PICA Power piezo actuator, 60 $\mu\text{m}$ travel range, OD 56 mm $\times$ L 63 mm   |
| P-056.80P | PICA Power piezo actuator, 120 $\mu\text{m}$ travel range, OD 56 mm $\times$ L 116 mm |
| P-056.90P | PICA Power piezo actuator, 180 $\mu\text{m}$ travel range, OD 56 mm $\times$ L 169 mm |

### PICA Thru ring actuators

| Model     | Description  |
|-----------|--|
| P-010.00H | PICA Thru piezo actuator, 5 $\mu$ m travel range, OD 10 mm $\times$ ID 5 mm $\times$ L 7 mm    |
| P-010.10H | PICA Thru piezo actuator, 15 $\mu$ m travel range, OD 10 mm $\times$ ID 5 mm $\times$ L 15 mm  |
| P-010.20H | PICA Thru piezo actuator, 30 $\mu$ m travel range, OD 10 mm $\times$ ID 5 mm $\times$ L 27 mm  |
| P-010.40H | PICA Thru piezo actuator, 60 $\mu$ m travel range, OD 10 mm $\times$ ID 5 mm $\times$ L 54 mm  |
| P-016.00H | PICA Thru piezo actuator, 5 $\mu$ m travel range, OD 16 mm $\times$ ID 8 mm $\times$ L 7 mm    |
| P-016.10H | PICA Thru piezo actuator, 15 $\mu$ m travel range, OD 16 mm $\times$ ID 8 mm $\times$ L 15 mm  |
| P-016.20H | PICA Thru piezo actuator, 30 $\mu$ m travel range, OD 16 mm $\times$ ID 8 mm $\times$ L 27 mm  |
| P-016.40H | PICA Thru piezo actuator, 60 $\mu$ m travel range, OD 16 mm $\times$ ID 8 mm $\times$ L 52 mm  |
| P-025.10H | PICA Thru piezo actuator, 15 $\mu$ m travel range, OD 25 mm $\times$ ID 16 mm $\times$ L 16 mm |
| P-025.20H | PICA Thru piezo actuator, 30 $\mu$ m travel range, OD 25 mm $\times$ ID 16 mm $\times$ L 27 mm |
| P-025.40H | PICA Thru piezo actuator, 60 $\mu$ m travel range, OD 25 mm $\times$ ID 16 mm $\times$ L 51 mm |
| P-025.50H | PICA Thru piezo actuator, 80 $\mu$ m travel range, OD 25 mm $\times$ ID 16 mm $\times$ L 66 mm |



## 3.2 Product View

The figure serves as an example and can differ from your model.

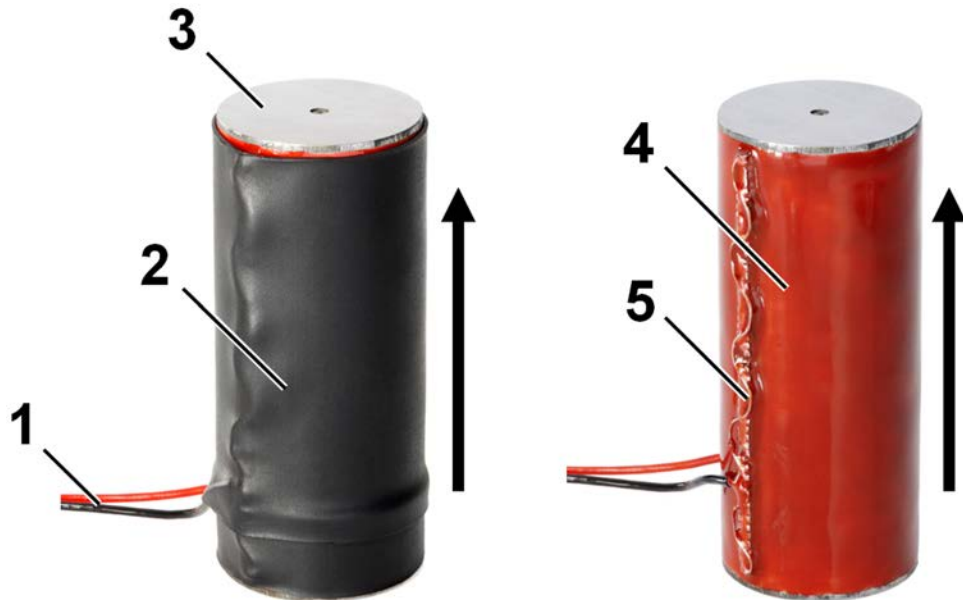

Figure 1: Example of product view

- 1 Stranded wires
- 2 Outer lateral surface (model-dependent):  
PICA Stack and PICA Thru: Shrink tubing, polyolefin, black  
PICA Power: Shrink tubing, FEP, transparent
- 3 End piece (model-dependent):  
PICA Stack and PICA Power: Steel disk  
PICA Thru: Ceramic ring (passive PZT)
- 4 Inner lateral surface: Protective polymer layer
- 5 Contact strip

The arrows in the figure indicate the expansion direction of the piezo actuator when a positive voltage is applied.

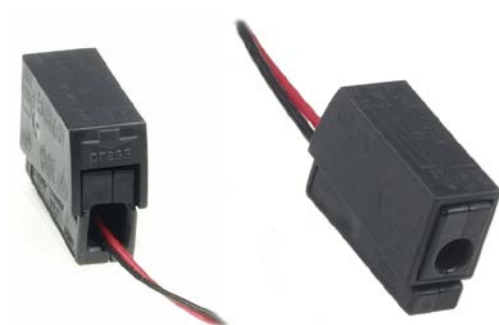

Figure 2: INYY-0005 shorting clamp: Front side for clamping the stranded wires (left) and rear side of the clamp (right)

### 3.3 Product Labeling

A label containing the following information is affixed to the black stranded wire of the P-0xx:

| Labeling                   | Description   |
|----------------------------|---|
|                            | Data matrix code (example; contains the serial number)  |
| P-016.10H                  | Product name (example), the places after the point refer to the model   |
| 214003005                  | Serial number (example), individual for each P-0xx<br>Meaning of the places (counting from left):<br>1 = internal information<br>2 and 3 = manufacturing year<br>4 to 9 = consecutive numbers |
| Country of origin: Germany | Country of origin   |
| WWW.PICERAMIC.COM          | Manufacturer's address (website)  |
|                            | Manufacturer's logo   |

### 3.4 Scope of Delivery

| Item ID   | Description   |
|-----------|---|
| P-0xx     | Piezo actuator according to order (p. 9)  |
| INYY-0005 | Shorting clamp 2.5 mm <sup>2</sup> for the stranded wires of the piezo actuator |
| PZ257EK   | Short instructions for piezo actuators without case                             |

### 3.5 Suitable Electronics

To operate a P-0xx, you need electronics. The device is selected depending on the type of application. The table below lists the suitable products.

| Item ID   | Description  |
|-----------|--|
| E-421.00  | High-power piezo amplifier module, without case, 1100 V voltage range, 550 W, integrated power supply                  |
| E-470.20  | High-power piezo amplifier, 1100 V voltage range, 550 W, bench-top device  |
| E-471.20  | High-power piezo amplifier, 1100 V voltage range, 550 W, prepared for servo controller and display / PC interface, 19" |
| E-472.20  | 2-channel high-power piezo amplifier, 1100 V voltage range, 550 W, 19"   |
| E-462.00  | HVPZT piezo amplifier, 10 to 1000 V, bench-top device  |
| E-462.OE1 | HVPZT piezo amplifier module, 10 to 1000 V, OEM version  |
| E-464.00  | HVPZT piezo amplifier, 3 channels, 1100 V voltage range, bench-top device  |
| E-481.00  | High-power piezo amplifier / controller with energy recovery, 1100 V voltage range, 2000 W, 19"                        |
| E-482.00  | PICA high-power piezo amplifier / controller with energy recovery, 1050 V, 6 A, 19"                                    |

| Item ID | Description  |
|---------|--|
| E-500   | Modular piezo amplifier (configuration example)<br>High-voltage piezo amplifier for PICA HVPZT, 3 channels, with PC interface and display, consisting of:<br>1 × E-500.00<br>19" case for modular piezo controller system, 1 to 3 channels<br>3 × E-508.00<br>HVPZT piezo amplifier module, 3 to 1100 V, 1 channel<br>1 × E-517.i3<br>Interface/display module, 24 bit D/A, TCP/IP, USB, RS-232, IEEE488, 3 channels |

- To order, contact our customer service department (p. 53).
- Before selecting electronics, calculate the power requirements of your application (p. 44).

### 3.6 Accessories

The P-202.xx cable is for connecting the P-0xx to the electronics.

| Item ID                             | Description                             |
|-------------------------------------|---|
| P-202.06                            | PICA HVPZT cable LEMO / open end, 0.6 m |
| P-202.10                            | PICA HVPZT cable LEMO / open end, 1 m   |
| P-202.12                            | PICA HVPZT cable LEMO / open end, 2 m   |
| P-202.13                            | PICA HVPZT cable LEMO / open end, 3 m   |
| P-202.15                            | PICA HVPZT cable LEMO / open end, 5 m   |
| Connector: LEMO FGG.0B.701.CJA.1173 |   |
| Cable: PUR cable, 2-wire, shielded  |   |

- To order, contact our customer service department (p. 53).

## 3.7 Technical Features

### **PICA piezo actuators**

P-0xx are PICA high-load piezo actuators for static and dynamic applications. They provide a micro-second response and sub-nanometer resolution.

PICA high-load piezo actuators are manufactured from piezo ceramic disks in a stack construction. The high load capacity makes them ideal for applications such as precision manufacturing and active vibration damping.



## 4 Unpacking

### NOTICE



#### **Destruction of the piezo actuator by impurities!**

Impurities on the surface of the P-0xx can result in the piezo actuator being destroyed by electric flashovers during operation.

- When handling the piezo actuator, wear powder-free nitrile or latex gloves and suitable protective goggles.
- Prevent the ceramic insulation or polymer insulation from coming into contact with conductive liquids (e.g. finger sweat) and conductive materials (e.g. metal dust).
- If the piezo actuator has been accidentally contaminated, clean it in accordance with the instructions in "Cleaning the P-0xx" (p. 49).

1. Unpack the P-0xx with care.
2. Compare the contents against the items covered by the contract and against the packing list.
3. Inspect the contents for signs of damage. If there is any sign of damage or missing parts, contact PI Ceramic immediately.
4. Keep all packaging materials in case the product needs to be returned.





## 5 Installation

### In this Chapter

|  |    |
|--|----|
| General Notes on Installation .....                        | 21 |
| Mounting the P-0xx.....                                    | 26 |
| Applying a Preload .....                                   | 27 |
| Applying the Load.....                                     | 28 |
| Connecting the P-0xx to the Electronics .....              | 29 |
| Connecting the Temperature Sensor to the Electronics ..... | 32 |

### 5.1 General Notes on Installation

#### **DANGER**



#### **Dangerous voltage and residual charge on piezo actuators!**

Temperature changes and compressive stresses can induce charges in the P-0xx piezo actuator. After being disconnected from the electronics, the piezo actuator can stay charged for several hours. Touching the live parts of the P-0xx can result in serious injury or death from electric shock.

- Do **not** touch the P-0xx unless it is discharged (p. 45).
- When handling the piezo actuator, wear powder-free nitrile or latex gloves and suitable protective goggles.
- Keep the piezo actuator short-circuited (p. 47) when it is not connected to the electronics.
- Do **not** disassemble the piezo actuator.

**NOTICE****Destruction of the piezo actuator by discharging too quickly!**

If the P-0xx is not connected to the electronics, the stranded wires must be short-circuited in order to prevent the piezo actuator from charging during temperature changes and compressive stresses. Unsuitable short-circuiting leads to an abrupt contraction of the piezo actuator due to excessively fast discharging. Abrupt contraction can destroy the piezo actuator.

- Remove the supplied shorting clamp (p. 15) from the stranded wires only if this is required for installation or operation.
- If the shorting clamp has been removed:
  - Ensure adequate protection against touching live parts.
  - Short-circuit the stranded wires of the P-0xx using a **10 kΩ discharge resistor** or discharge the piezo actuator (p. 45) in a suitable manner before reconnecting the shorting clamp.

**NOTICE****Destruction of the piezo actuator by loads that are too high!**

Excessive loads can destroy the P-0xx.

- Do **not** exceed the maximum compressive/tensile stress capacity (p. 60).

**NOTICE****Damage to the piezo actuator from excessive preloads!**

Excessive preload can mechanically depolarize the piezo actuator. Depolarization damages the piezo actuator.

- Only apply preloads that are just as high as necessary.
- Do **not** exceed the maximum preload (p. 60).

**NOTICE****Destruction of the piezo actuator by mechanical overload!**

Torques, bending forces and lateral forces can destroy the piezo actuator.

- Avoid torques, bending forces and lateral forces on the piezo actuator.
- Make sure that the center of load of the moving system is on the motion axis of the piezo actuator.
- Avoid an uneven load distribution by using suitable structures or guide elements (e.g. ball tips or flexure guides).
- Establish contact over as large an area as possible on the end surfaces of the piezo actuator, and select opposing surfaces with an evenness of only a few micrometers. Minor unevenness can be compensated by full-surface gluing, for example.

**NOTICE****Damage from removing the shrink tubing from the piezo actuator!**

The shrink tubing on the piezo actuator prevents contamination and serves as a strain relief for the stranded wires. Contamination of the piezo ceramics and/or inadmissible forces on the stranded wires can damage the piezo actuator.

- Remove the shrink tubing only if necessary and only if the piezo actuator is installed in the location where it is to be operated.
- If the shrink tubing has to be removed, ensure that the surface of the piezo actuator does not become scratched in the process.

If the shrink tubing has been removed:

- Do **not** touch the outer surface or the contact strips of the piezo actuator.
- Avoid tensile stress on the stranded wires of the piezo actuator.

**NOTICE****Damage due to scratches on the surface of the piezo actuator!**

The surface of the piezo actuator is scratch-sensitive. Scratches on the surface can cause damage to the piezo actuator.

- Do **not** use metal tools to install the piezo actuator.
- Install the piezo actuator so that no scratches can occur on the ceramic or polymer insulation or on the end surfaces of the piezo actuator during installation and operation.

**NOTICE**



**Heating up of the P-0xx during operation!**

The heat produced during operation of the P-0xx can affect your application.

- Install the P-0xx so that your application is not affected by the dissipating heat.

**INFORMATION**

Ground loops can occur when the shield of the connection cable of the P-0xx is connected to an actuator case that is additionally grounded via a separate protective earth conductor.

- If a ground loop occurs, contact our customer service department (p. 53).

Piezo actuators may only be loaded axially. Moreover, piezo actuators should be preloaded (p. 27) in order to avoid tensile stresses. The following figures are to help you avoid mounting errors.

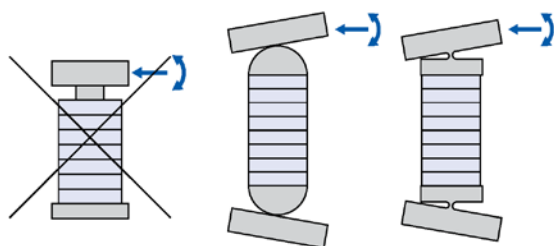

Figure 3: Prevention of lateral forces and torques

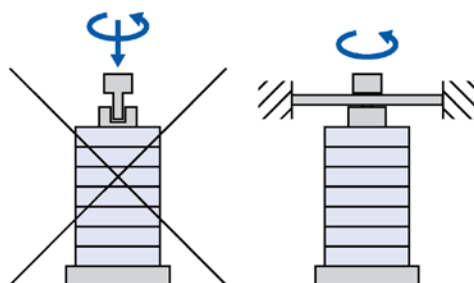

Figure 4: Prevention of torques

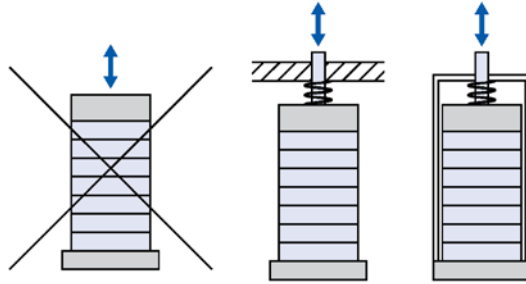

Figure 5: Prevention of tensile stresses by means of a mechanical preload

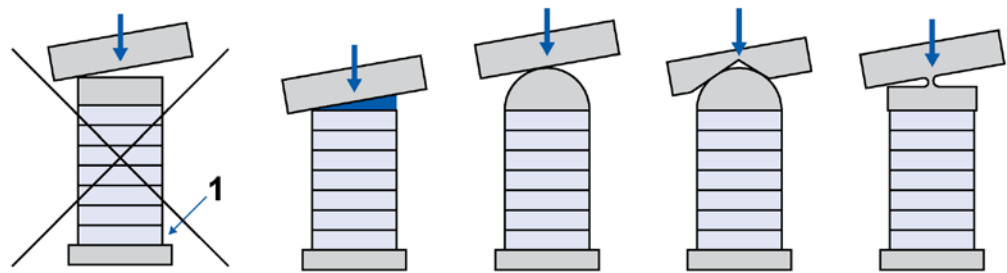

Figure 6: Prevention of an irregular load application (1: Tensile stresses)

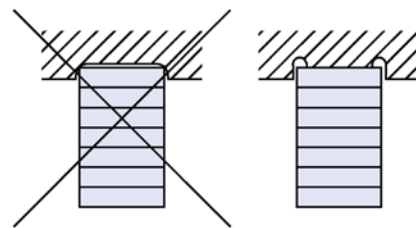

Figure 7: Full-area contact of the piezo actuator

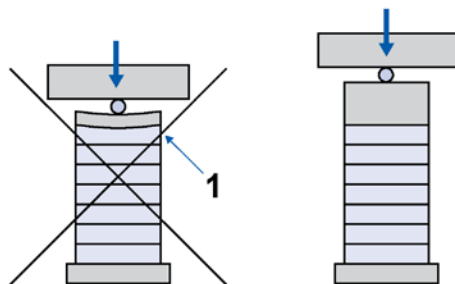

Figure 8: Proper dimensioning of the end pieces in the case of point contact (1: Tensile stresses)

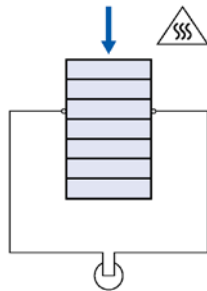

Figure 9: Mechanical or thermal loads electrically charge the piezo actuator. Mounting only when short-circuited.

## 5.2 Mounting the P-0xx

P-0xx piezo actuators are glued to metal or ceramic surfaces.

### Prerequisite

- ✓ You have read and understood the general notes on installation (p. 21).
- ✓ The P-0xx is discharged (p. 45) and short-circuited (p. 47).

### Tools and accessories

- Grease-free and even surface
- Suitable adhesive (e.g. cold-hardening epoxy resin adhesive)

### Mounting the P-0xx

- Glue the piezo actuator to the surface:
  - Apply the thinnest possible layer of adhesive.
  - During the hardening process, maintain the operating temperature range (p. 61) specified for the piezo actuator.
  - Observe the temperature expansion coefficients of the materials involved.

## 5.3 Applying a Preload

The tensile stress capacity of the piezo actuator is relatively low. It is therefore recommended to mechanically preload the piezo actuators in the application, either externally in the mechanical structure or internally in a case.

### Prerequisite

- ✓ You have read and understood the general notes on installation (p. 21).
- ✓ The P-0xx is discharged (p. 45) and short-circuited (p. 47).

### Tools and accessories

- When installing in a case: Suitable case
- Suitable guide elements
- When creating the preload with a spring:

Suitable preload spring with the following characteristics:

- The stiffness of the preload spring does not exceed 10 % of the stiffness (p. 55) of the piezo actuator. This is to minimize the displacement loss. If the stiffness of the preload spring is equal to that of the actuator, the free displacement drops by half.
- With highly dynamic applications:  
The resonant frequency of the preload spring exceeds that of the piezo actuator.

### Applying a preload

- Apply the preload near the axis within the core cross-section of the piezo actuator.

## 5.4 Applying the Load

The P-0xx can be coupled to a load in various ways, depending on the application:

- Gluing the piezo actuator (p. 26) into the mechanical system to be moved or into a flexure joint
- Using a ball tip:
  - Gluing a hardened ball tip with point contact to an even counter face
  - Gluing a hardened ball tip with ring contact to a spherical calotte

### **INFORMATION**

Diagrams showing how to couple the P-0xx to a load can be found in "General Notes on Installation" (p. 21).

### **Prerequisite**

- ✓ You have read and understood the general notes on installation (p. 21).
- ✓ The P-0xx is discharged (p. 45) and short-circuited (p. 47).

### **Tools and accessories**

- Suitable adhesive (e.g. cold-hardening epoxy resin adhesive)
- When using a ball tip: Suitable ball tip
- When using a flexure joint: Suitable flexure joint

### **Applying the load**

- Apply the load evenly.

If the piezo actuator is coupled in a milling pocket:

- Ensure that there is full-area contact at the end surface of the piezo actuator. For this purpose, choose the dimensions of the milling pocket correspondingly or make free cuts in the milling pocket.

If a point load is applied to the end piece of the piezo actuator:

- Dimension the end piece so that its thickness corresponds to half the cross-sectional dimension in order to prevent tensile stresses on the piezo actuator.



## 5.5 Connecting the P-0xx to the Electronics

The piezo actuator P-0xx can be connected to the electronics as follows:

- Using a suitable connection cable (not included in scope of delivery) and a suitable LEMO connector (available on request)
- Alternative: Using the P-202.xx connection cable (see "Accessories", p. 16), which is equipped with the LEMO FGG.0B.701.CJA.1173 connector

### INFORMATION

The stranded wires of the P-0xx and the wires of the P-202.xx connection cable are color-coded:

- Red: Voltage connection (+)
- Black: Ground (-)

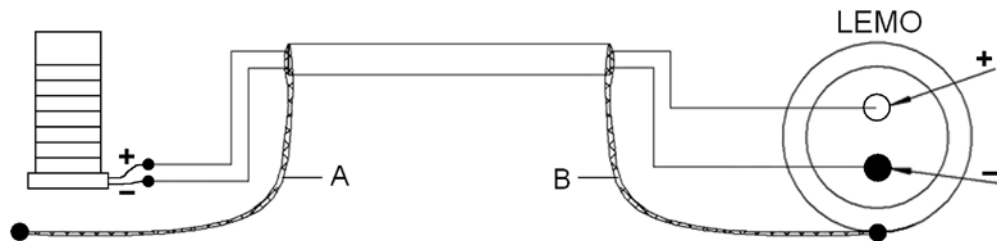

Figure 10: Piezo actuator P-0xx (left) to LEMO connector (right) when using a connection cable soldered on both sides

|      |  |
|------|--|
| A    | Cable shield (actuator side)   |
| B    | Cable shield (connector side)  |
| LEMO | LEMO connector   |
| +    | On the piezo actuator (left): Red stranded wire for voltage connection<br>On the LEMO connector (right): Female contact for voltage connection |
| -    | On the piezo actuator (left): Black stranded wire for ground<br>On the LEMO connector (right): Male contact for ground                         |

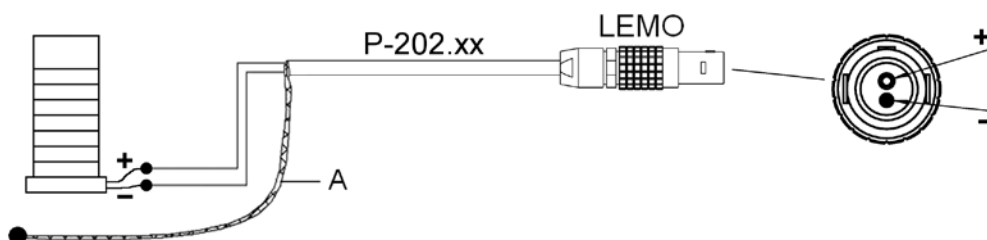

Figure 11: Piezo actuator P-0xx (left) to LEMO connector (right) when using the P-202.xx connection cable

|          |   |
|----------|---|
| A        | Cable shield (actuator side)  |
| P-202.xx | Cable for connecting the P-0xx to the electronics   |
| LEMO     | LEMO connector  |
| +        | On the piezo actuator (left): Red stranded wire for voltage connection<br>On the LEMO connector (right): Female contact for voltage connection (connected to the red wire of the P-202.xx connection cable) |
| -        | On the piezo actuator (left): Black stranded wire for ground<br>On the LEMO connector (right): Male contact for ground (connected to the black wire of the P-202.xx connection cable)                       |

### Prerequisite

- ✓ You have read and understood the general notes on installation (p. 21).
- ✓ You have read and understood the user manual of the electronics used.
- ✓ If the P-0xx is not short-circuited: The P-0xx is discharged (p. 45).
- ✓ The electronics is **switched off**.

### Tools and accessories

- When using a connection cable soldered on both ends:
  - Suitable LEMO connector (available on request)
  - Shielded 2-wire cable (not included in scope of delivery) which complies with the voltage and current specifications of the electronics (p. 15) to be connected and meets the applicable standards with regard to the conditions of use
- When using the P-202.xx connection cable:
  - P-202.xx connection cable (see "Accessories", p. 16)
- Suitable soldering iron
- Suitable solder
- Suitable cable tools

### **Connecting the P-0xx to the electronics (by means of a connection cable to be soldered on both sides)**

1. If necessary, shorten the wires and the cable shield of the connection cable to the correct length.
2. Solder the LEMO connector to the wires of the connection cable as shown in the connection diagram.
3. Connect the cable shield on the connector side (B) to the connector shell.
4. Make the stranded wires of the P-0xx accessible:
  - If the P-0xx is short-circuited, separate the short-circuited stranded wires of the P-0xx from each other.
  - If a shorting clamp (p. 15) or a discharge resistor is connected, remove this component from the stranded wires.
5. Solder the stranded wires of the P-0xx to the wires of the connection cable as shown in the connection diagram:
  - a) Solder the red stranded wire of the P-0xx to the wire of the connection cable that is connected to the female contact of the LEMO connector.
  - b) Solder the black stranded wire of the P-0xx to the wire of the connection cable that is connected to the male contact of the LEMO connector.
  - c) Insulate the soldered cable connections in a suitable manner.
6. Connect the cable shield on the actuator side (A) to the actuator case and insulate it. If there is no actuator case, cut the shield on the actuator side and insulate it.
7. Connect the connector of the P-0xx to the corresponding connection on the electronics.

### **Connecting the P-0xx to the electronics (by means of a P-202.xx connection cable)**

1. Make the stranded wires of the P-0xx accessible:
  - If the P-0xx is short-circuited, separate the short-circuited stranded wires of the P-0xx from each other.
  - If a shorting clamp (p. 15) or a discharge resistor is connected, remove this component from the stranded wires.
2. If necessary, shorten the wires and the cable shield of the P-202.xx connection cable to the correct length.

3. Solder the stranded wires of the P-0xx to the wires of the P-202.xx connection cable as shown in the connection diagram:
  - a) Solder the red stranded wire of the P-0xx to the red wire of the P-202.xx connection cable.
  - b) Solder the black stranded wire of the P-0xx to the black wire of the P-202.xx connection cable.
  - c) Insulate the soldered cable connections in a suitable manner.
4. Connect the cable shield on the actuator side (A) to the actuator case and insulate it. If there is no actuator case, cut the shield on the actuator side and insulate it.
5. Connect the connector of the P-0xx to the corresponding connection on the electronics.

## 5.6 Connecting the Temperature Sensor to the Electronics

The P-010.xxP - P-056.xxP models have a PT 1000 temperature sensor which can be connected to the E-481 and E-482 electronics by means of a suitable LEMO connector (available on request).

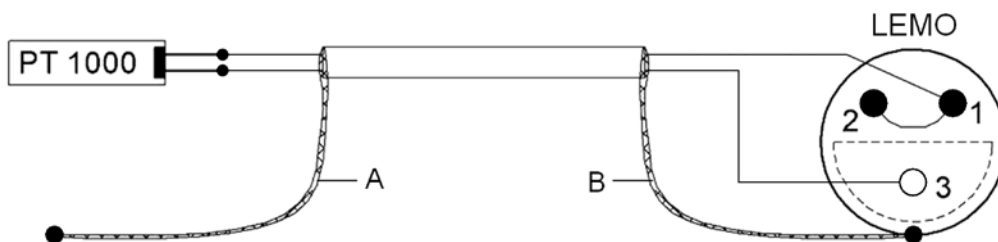

Figure 12: PT1000 temperature sensor to LEMO connector

|                |   |
|----------------|---|
| <i>PT 1000</i> | <i>PT1000 temperature sensor</i>                                    |
| <i>LEMO</i>    | <i>LEMO connector (soldering side; Pin 1 and Pin 2 are bridged)</i> |
|                | <i>1 = Output: Temp_SA</i>  |
|                | <i>2 = Output: Temp_S</i>   |
|                | <i>3 = GND: Ground</i>  |
| <i>A</i>       | <i>Cable shield (actuator side)</i>                                 |
| <i>B</i>       | <i>Cable shield (connector side)</i>                                |

### Prerequisite

- ✓ You have read and understood the general notes on installation (p. 21).
- ✓ The P-0xx is discharged (p. 45) and short-circuited (p. 47).
- ✓ The electronics is **switched off**.

### Tools and accessories

- Suitable connector: LEMO FFA.0S.303.CLA (available on request)
- Shielded 2-wire cable (not included in scope of delivery)
- Suitable soldering iron
- Suitable solder
- Suitable cable tools

### Connecting the temperature sensor to the electronics

1. If necessary, shorten the wires and the cable shield of the connection cable to the correct length.
2. Solder the LEMO connector to the wires of the connection cable as shown in the connection diagram.
3. Connect the cable shield on the connector side (B) to the connector shell.
4. Solder the stranded wires of the temperature sensor to the wires of the connection cable as shown in the connection diagram. The polarity of the stranded wires on the temperature sensor is not relevant.
5. Connect the cable shield on the actuator side (A) to the actuator case and insulate it. If there is no actuator case, cut the shield on the actuator side and insulate it.
6. Connect the connector of the temperature sensor to the corresponding connection on the electronics.



## 6 Start-Up and Operation

### In this Chapter

|   |    |
|---|----|
| General Notes on Start-Up and Operation ..... | 35 |
| Determining the Operating Parameters.....     | 40 |
| Operating the P-0xx.....                      | 45 |
| Discharging the P-0xx .....                   | 45 |
| Short-Circuiting the P-0xx.....               | 47 |

### 6.1 General Notes on Start-Up and Operation

#### **DANGER**



#### **Dangerous voltage on piezo actuators during operation!**

During operation, the P-0xx carries voltages of up to 1000 V. The shrink tubing of the piezo actuator and protective polymer layer beneath do **not** provide contact protection against electric shock. Touching the live parts of the P-0xx can result in serious injury or death from electric shock.

- Do **not** touch the piezo actuator during operation.
- Electrically insulate the piezo actuator from the surrounding mechanical system to prevent direct or indirect contact with live parts. Observe the clearances and creepage distances required for the operating voltage, and observe the standards applicable to your application.

**DANGER****Risk of electric shock if the protective earth conductor is not connected!**

The system into which the P-0xx is integrated (e.g. case or surrounding mechanical system) must be connected to a protective earth conductor. If the protective earth conductor is missing or not properly connected, dangerous touch voltages can occur on the overall system in case of malfunction or failure of the system. If touch voltages exist, touching the overall system can result in serious injury or death from electric shock.

- Before start-up, connect the overall system to a protective earth conductor in accordance with the applicable standards.
- Do **not** remove the protective earth conductor during operation.
- If the protective earth conductor has to be temporarily removed (e.g. for modifications), reconnect the overall system to the protective earth conductor before starting it up again.

**CAUTION****Burning from hot surface!**

The surface of the P-0xx and its vicinity can heat up during operation. Touching the P-0xx and surrounding parts can result in minor injuries from burning.

- Cool the P-0xx so that the temperature of its surface and surrounding parts does **not** exceed 65 °C.
- If sufficient cooling is not possible: Make sure that the hot P-0xx and its surrounding parts **cannot** be touched.
- If sufficient cooling and protection against contact are not possible: Mark the danger zone in accordance with the legal regulations.



**NOTICE****Destruction of the piezo actuator by electric flashovers!**

The use of the P-0xx in environments that increase the electrical conductivity can lead to the destruction of the piezo actuator by electric flashovers. Electric flashovers can be caused by moisture, high humidity, liquids and conductive materials such as metal dust. In addition, electric flashovers can also occur in certain air pressure ranges due to the increased conductivity of the air.

- Avoid operating the P-0xx in environments that can increase the electrical conductivity.
- Only operate the P-0xx within the permissible ambient conditions and classifications (p. 61).
- Prevent the piezo actuator from coming into contact with liquids. If liquid cooling is to be used, contact our customer service department (p. 53).
- Protect the piezo actuator from moisture by means of hermetic sealing or the supply of dry air.
- In the air pressure range between 1 hPa and 500 hPa:  
Do **not** operate the P-0xx, or operate it only at reduced voltage (max. 200 V).
- For operation in vacuum below 0.1 hPa:  
Do **not** operate the P-0xx during evacuation.
- If the P-0xx is to be operated in a special gas atmosphere, contact our customer service department (p. 53).

**NOTICE****Destruction of the piezo actuator by dynamic forces!**

During dynamic operation, dynamic forces can occur that cancel the preload of the piezo actuator. Operation without a preload can destroy the actuator.

- Do **not** exceed the maximum compressive/tensile stress capacity (p. 60).
- Observe the notes in "Determining the Operating Parameters" (p. 40).

**NOTICE****Destruction of the piezo actuator by operating frequencies that are too high!**

An excessive operating frequency can cause thermal and mechanical overload, thereby destroying the piezo actuator.

- Select the operating frequency so that the following conditions are met:
  - The operating frequency of the piezo actuator does not exceed one third of the resonant frequency. The resonant frequencies given in the data tables (p. 55) apply to operation of the piezo actuator when it is unloaded and not clamped on both sides. In an arrangement with unilateral clamping, the value has to be divided in half. For loaded piezo actuators that are clamped on one side, see "Calculating the Maximum Operating Frequency of the Loaded Piezo Actuator" (p. 42).
  - The dynamic forces occurring during operation do **not** exceed the maximum tensile/compressive stress capacity of the piezo actuator (see "Calculating the Forces that Occur During Dynamic Operation" (p. 43) and "Compressive/Tensile Stress Capacity and Preload" (p. 60)).
- If your application involves the operation of a piezo actuator which is not clamped on both sides, contact our customer service department (p. 53).

**NOTICE****Damage due to steep edges in the control signal!**

If the actuator does not have a preload, steep edges in the control signal can trigger strong dynamic forces which damage the piezo actuator. Steep edges can occur, for example, when digital wave generators are switched on.

- Avoid steep edges in the control signal on actuators with low preload.

**NOTICE****Damage from reconnecting a charged piezo actuator!**

The piezo actuator can remain charged if its connection cable is pulled out of the electronics during operation. Reconnecting a charged piezo actuator to electronics that is still running can cause a mechanical impulse which damages the piezo actuator.

- Do **not** pull out the connection cable of the piezo actuator from the electronics during operation.

If the connection cable of the piezo actuator is accidentally pulled out of the electronics during operation:

- Switch off the electronics before you reconnect the piezo actuator.

**NOTICE****Reduced lifetime due to permanently high voltage and high air humidity!**

The permanent application of a high static voltage to piezo actuators leads to a considerable reduction in the lifetime of the piezo ceramic of the actuator. This applies in particular to operation in a humid environment.

- When the P-0xx is not in use but the electronics remains switched on to ensure temperature stability, discharge the P-0xx (p. 45).
- If possible: Limit the maximum operating voltage to 750 V during continuous operation.
- Reduce offset voltages to a minimum.
- Protect the piezo actuator from moisture by means of hermetic sealing or the supply of dry air.
- Make sure that the air humidity in the vicinity of the P-0xx does not exceed the relative humidity given in "Ambient Conditions and Classifications" (p. 61).

**NOTICE****Operating voltage too high or incorrectly connected!**

Operating voltages that are too high or incorrectly connected can cause damage to the P-0xx.

- Do **not** exceed the operating voltage range (p. 58) for which the P-0xx is specified.
- Operate the P-0xx only when the operating voltage is properly connected; see "Connecting the P-0xx to the Electronics" (p. 29).

**NOTICE****Destruction of the piezo actuator by overheating!**

Overheating can destroy the piezo actuator.

- Cool the piezo actuator.
- Monitor the temperature of the piezo actuator with a temperature sensor.
- Adjust the operating voltage, operating frequency and/or operating time so that the maximum operating temperature of the piezo actuator is not exceeded, see "Ambient Conditions and Classifications" (p. 61), "Maximum Ratings" (p. 58) and "Determining the Operating Parameters" (p. 40).

**NOTICE****Destruction of the piezo actuator by cooling too quickly!**

If the cooling is too fast, the resulting thermomechanical load can destroy the piezo actuator.

- Ensure that the piezo actuator cools down slowly to room temperature.
- Connect additional cooling systems only when the piezo actuator has cooled down to room temperature.

**NOTICE****Uncontrolled oscillation!**

Oscillations can cause irreparable damage to the piezo actuator. Oscillations are indicated by a humming and can result from the following causes:

- A change in the load and/or dynamics requires the servo-control parameters to be adjusted.
- The piezo actuator is operated near its resonant frequency.

If you notice oscillations:

- In closed-loop operation, immediately switch off the servo mode.
- In open-loop operation, immediately stop the piezo actuator.

**INFORMATION**

The positive direction of motion (p. 13) corresponds to the expansion direction of the piezo actuator when a positive voltage is applied.

## 6.2 Determining the Operating Parameters

**INFORMATION**

For the determination of the operating parameters, it is assumed that the piezo actuator is clamped on one side.

- If you require operating parameters for the two-sided free operation of the piezo actuator, contact our customer service department (p. 53).

## 6.2.1 Overview of Limiting Factors

Limiting factors for the operation of the piezo actuator:

- Resonant frequency:

The resonant frequency of the piezo actuator serves as a basis for calculating the operating frequency, which must **not** exceed one third of the resonant frequency. The resonant frequencies given in the data tables (p. 55) apply to operation of the piezo actuator when it is unloaded and not clamped on both sides. In an arrangement with unilateral clamping, the value has to be divided in half.

For **loaded** piezo actuators that are clamped on one side, see "Calculating the Maximum Operating Frequency of the Loaded Piezo Actuator" (p. 42).

- Maximum compressive/tensile stress capacity (p. 60):

The mass of the load to be moved, the preload and the operating frequency of the piezo actuator must be selected so that the dynamic forces occurring during operation do not exceed the maximum tensile/compressive stress capacity of the piezo actuator. See "Calculating the Forces that Occur During Dynamic Operation" (p. 43).

- Maximum permissible operating temperature of the piezo actuator (p. 61):

The greater the operating frequency, the operating voltage (peak-to-peak), and the capacitance of the piezo actuator, the greater the thermal power generated in the piezo actuator. The operating frequency, operating voltage and operating time must be selected so that the maximum permissible operating temperature of the piezo actuator is **not** exceeded. For the maximum permissible operating frequency without cooling, see column B of the table in "Maximum Ratings" (p. 58).

When cooling measures are used, the limit values for the operating frequency, operating voltage and operating time increase. The use of a temperature sensor (p. 16) can prevent the piezo actuator from overheating.

- Peak and average output current of the electronics (p. 15) used:

The electronics must be selected so that it can supply the required currents. See "Calculating the Power Requirement for Sinusoidal Operation" (p. 44).

## 6.2.2 Calculating the Effective Mass

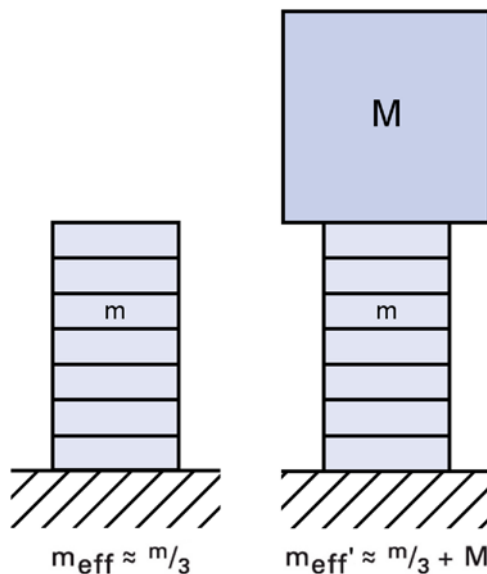

Figure 13: Calculation of the effective mass of a unilaterally clamped piezo stack actuator without load (left) and with additional load (right).

1. Determine the mass  $m$  of your piezo actuator.
2. Determine the additional load  $M$ .
3. Calculate the effective mass  $m_{\text{eff}}$  of the unloaded piezo actuator and  $m_{\text{eff}}'$  of the loaded piezo actuator using the formulas in the figure above.

## 6.2.3 Calculating the Maximum Operating Frequency of the Loaded Piezo Actuator

### INFORMATION

In the following calculation, the maximum permissible operating temperature of the piezo actuator is **not** taken into account. During operation without cooling, the maximum operating temperature may already be exceeded when the operating frequency is still below the limit value calculated in the following.

- For the maximum permissible operating frequency without cooling, see column B of the table in "Maximum Ratings" (p. 58).

1. Calculate the resonant frequency of the loaded, unilaterally clamped piezo actuator using the following formula:

$$f_0' = f_0 \sqrt{\frac{m_{\text{eff}}}{m_{\text{eff}}'}}$$

$f_0'$  = Resonant frequency of the loaded piezo actuator [Hz]

$f_0$  = Resonant frequency of the unloaded piezo actuator [Hz]: The resonant frequencies given in the data tables (p. 55) apply for the two-sided free operation. In an arrangement with unilateral clamping, the value has to be divided in half.

$m_{\text{eff}}$  = Effective mass; approx. 1/3 of the mass of the piezo actuator [kg]

$m_{\text{eff}}'$  = Effective mass  $m_{\text{eff}}$  + additional load M [kg]

See also "Calculating the Effective Mass" (p. 42).

2. Calculate the maximum operating frequency of the loaded, unilaterally clamped piezo actuator using the following formula:

$$f_{\text{max}} = f_0'/3$$

$f_{\text{max}}$  = Maximum operating frequency of the loaded piezo actuator [Hz]

$f_0'$  = Resonant frequency of the loaded piezo actuator [Hz]

## 6.2.4 Calculating the Forces that Occur During Dynamic Operation

- Calculate the dynamic forces acting on the unilaterally clamped piezo actuator during sinusoidal operation at the frequency  $f$  using the following formula:

$$F_{\text{dyn}} \approx \pm 4\pi^2 \cdot m_{\text{eff}}' \left(\frac{\Delta L}{2}\right) f^2$$

$F_{\text{dyn}}$  = Dynamic force [N]

$m_{\text{eff}}'$  = Effective mass  $m_{\text{eff}}$  (approx. 1/3 of the mass of the piezo actuator) + additional load M [kg], see also "Calculating the Effective Mass" (p. 42)

$\Delta L$  = Displacement in the application (peak-to-peak) [m]

$f$  = Frequency [Hz]

**Example:** The dynamic forces at 1000 Hz, 2  $\mu\text{m}$  displacement (peak-to-peak) and 1 kg effective mass are approximately  $\pm 40$  N.

## 6.2.5 Calculating the Power Requirement for Sinusoidal Operation

- Calculate the average current requirement for sinusoidal operation with the following formula:

$$I_a \approx f \cdot C \cdot U_{p-p}$$

- Calculate the peak current requirement for sinusoidal operation with the following formula:

$$I_{max} \approx f \cdot \pi \cdot C \cdot U_{p-p}$$

| Variable  | Description   | Notes   |
|-----------|---|---|
| $I_a$     | Required average current of the amplifier (source / sink) [A] | It is essential for the power supply to supply enough current.  |
| $I_{max}$ | Required peak current of the amplifier (source / sink) [A]    |   |
| f         | Operating frequency [Hz]                                      | Details on the operating frequency see "Overview of Limiting Factors" (p. 41).  |
| C         | Capacitance of the piezo actuator [F (= As/V)]                | See "Data Table" (p. 55) for the small-signal capacitance of the piezo actuator.<br>For large-signal conditions, a safety factor of 70 % should be added to the small-signal capacitance. |
| $U_{p-p}$ | Operating voltage (peak-to-peak) [V]                          |   |



## 6.3 Operating the P-0xx

### Prerequisite

- ✓ You have read and understood the general notes on start-up and operation (p. 35).
- ✓ You have determined the operating parameters for your application (p. 40).
- ✓ You have installed (p. 21) the P-0xx correctly and connected it to the electronics (p. 29).
- ✓ You have provided suitable electronics that can supply the required currents (p. 44).
- ✓ You have read and understood the user manual of the electronics used.

### Operating the P-0xx

- For starting up and operating the P-0xx, follow the instructions in the manual of the electronics (p. 15) used.

## 6.4 Discharging the P-0xx

The P-0xx must be discharged in the following cases:

- When the P-0xx is not in use but the electronics remains switched on to ensure temperature stability
- When the stranded wires of the P-0xx are to be short-circuited without a discharge resistor, e.g. with the shorting clamp (p. 47) supplied
- If the connection cable of the P-0xx is accidentally pulled out of the electronics during operation

### Prerequisite

- ✓ You have read and understood the general notes on installation (p. 21).
- ✓ You have read and understood the general notes on start-up and operation (p. 35).

### Tools and accessories

If the P-0xx is not connected to the electronics:

- Only for P-0xx **without** connector (condition as supplied):
  - 10 k $\Omega$  discharge resistor (not included in scope of delivery), the touchable parts of which are adequately insulated for the actuator's operating voltage range (p. 58)
- Only for P-0xx **with** connector (p. 29):
  - Electronics (p. 15) from PI or suitable shorting plug (available on request)

### Discharging a P-0xx connected to the electronics

- Set the piezo voltage to 0 V on the electronics.

### Discharging a P-0xx that is not connected to the electronics

If the P-0xx does **not** have a connector:

1. Ensure adequate protection against touching live parts.
2. Short-circuit the stranded wires of the P-0xx for at least a few seconds using a **10 k $\Omega$  discharge resistor**.

If the P-0xx has a connector (p. 29):

- Connect the voltage connector of the P-0xx to the switched off PI electronics, which has an internal discharge resistor, for at least a few seconds.
- Alternative: Connect a suitable shorting plug with integrated discharge resistor to the voltage connector of the P-0xx for at least a few seconds.

## 6.5 Short-Circuiting the P-0xx

The P-0xx must be discharged (p. 45) and short-circuited before demounting (e.g. before cleaning and transportation of the P-0xx) as well as for modifications.

### Prerequisite

- ✓ You have read and understood the general notes on installation (p. 21).
- ✓ You have discharged (p. 45) the P-0xx and disconnected it from the electronics.

### Tools and accessories

- Only for P-0xx **without** connector (condition as supplied):
  - Supplied shorting clamp (p. 15)
- Only for P-0xx **with** connector (p. 29):
  - Suitable shorting plug (available on request)

### Short-circuiting the P-0xx

If the P-0xx does **not** have a connector:

- Short-circuit the stranded wires of the **discharged** P-0xx using the supplied shorting clamp.

If the P-0xx has a connector (p. 29):

- Connect a suitable shorting plug with integrated discharge resistor to the voltage connector of the P-0xx.



## 7 Maintenance

### In this Chapter

|                                   |    |
|-----------------------------------|----|
| General Notes on Maintenance..... | 49 |
| Cleaning the P-0xx .....          | 49 |

### 7.1 General Notes on Maintenance

The P-0xx is maintenance-free.

### 7.2 Cleaning the P-0xx

#### NOTICE



#### **Destruction of the piezo actuator by electric flashovers!**

If it comes into contact with liquids, the piezo actuator can be destroyed by electric flashovers.

Before cleaning the P-0xx:

- Ensure that the P-0xx is discharged (p. 45) and short-circuited (p. 47).

After cleaning the P-0xx:

- Dry the P-0xx completely in a drying cabinet (recommended duration: 30 minutes at 40 °C).

#### **Prerequisites**

- ✓ The P-0xx is discharged (p. 45) and short-circuited (p. 47).
- ✓ The P-0xx is disconnected from the electronics.

### Cleaning the P-0xx

- Touch the piezo actuator only with powder-free nitrile or latex gloves.
- Do **not** use acetone.
- When necessary, clean the surfaces of the P-0xx with a cloth that is slightly dampened with a mild cleanser (e.g. ethanol or isopropanol).
- When cleaning in an ultrasonic bath:
  - Reduce the energy input to the necessary minimum.
  - Do not use any liquids other than isopropanol for cleaning.
  - Make sure that the cleaning time in the ultrasonic bath does **not** exceed two minutes.
- After cleaning, dry the P-0xx completely in a drying cabinet (recommended duration: 30 minutes at 40 °C).

## 8 Troubleshooting

| Problem              | Possible Causes   | Solution  |
|----------------------|---|---|
| No or limited motion | Cable is not connected correctly  | ➤ Check the cable connections.  |
|                      | Excessive load  | ➤ Do not exceed the maximum compressive/tensile stress capacity (p. 60).  |
|                      | The E-481 or E-482 electronics from PI has deactivated the voltage output due to overheating of the piezo actuator    | <p>If the piezo actuator is equipped with a PT 1000 temperature sensor, the E-481 and E-482 electronics evaluate the signal from the temperature sensor.</p> <ol style="list-style-type: none"> <li>1. Switch off the electronics.</li> <li>2. Wait a few minutes until the piezo actuator has sufficiently cooled down.</li> <li>3. Switch the electronics on again.</li> </ol> <p>Preventive measures:</p> <ul style="list-style-type: none"> <li>➤ Reduce the operating voltage, operating frequency and/or operating time.</li> <li>➤ Cool the piezo actuator.</li> </ul> |
|                      | The E-481 or E-482 electronics from PI has deactivated the voltage output because no temperature sensor is connected. | <p>If the piezo actuator is equipped with a PT 1000 temperature sensor:</p> <ul style="list-style-type: none"> <li>➤ Connect the PT 1000 temperature sensor to the electronics (p. 32).</li> </ul> <p>If there is no temperature sensor:</p> <ul style="list-style-type: none"> <li>➤ Connect the dummy connector supplied with the electronics to the temperature sensor socket of the electronics in order to activate the voltage output on the electronics.</li> </ul>  |
|                      | Piezo actuator is depolarized due to overheating or reverse polarity  | ➤ Contact our customer service department (p. 53).  |

| <b>Problem</b>                                | <b>Possible Causes</b>                 | <b>Solution</b>                                    |
|---|--|--|
| Piezo actuator contracts as the voltage rises | Reverse polarity of the piezo actuator | ➤ Contact our customer service department (p. 53). |

If the problem that occurred with your system is not listed in the table above or cannot be solved as described, contact our customer service department (p. 53).



## 9 Customer Service

For inquiries and orders, call PI Ceramic or send us an e-mail ([info@piceramic.de](mailto:info@piceramic.de)).

If you have questions concerning your system, have the following information ready:

- Product codes and serial numbers of all products in the system
- Firmware version of the controller (if present)
- Version of the driver or the software (if present)
- Operating system on the PC (if present)

The latest versions of the user manuals are available for download (p. 3) on our website.



## 10 Technical Data

### In this Chapter

|                      |    |
|----------------------|----|
| Specifications ..... | 55 |
| Dimensions .....     | 62 |

## 10.1 Specifications

### 10.1.1 Data Table

#### PICA Stack piezo actuators

|           | Displacement | Diameter OD | Length L | Blocking Force | Stiffness | Electrical Capacitance | Resonant Frequency |
|-----------|--------------|-------------|----------|----------------|-----------|------------------------|--------------------|
|           | $\mu m$      | $mm$        | $mm$     | $N$            | $N/\mu m$ | $nF$                   | $kHz$              |
| P-007.00  | 5            | 7           | 8        | 650            | 130       | 11                     | 126                |
| P-007.10  | 15           | 7           | 17       | 850            | 59        | 33                     | 59                 |
| P-007.20  | 30           | 7           | 29       | 1000           | 35        | 64                     | 36                 |
| P-007.40  | 60           | 7           | 54       | 1150           | 19        | 130                    | 20                 |
| P-010.00  | 5            | 10          | 8        | 1400           | 270       | 21                     | 126                |
| P-010.10  | 15           | 10          | 17       | 1800           | 120       | 64                     | 59                 |
| P-010.20  | 30           | 10          | 30       | 2100           | 71        | 130                    | 35                 |
| P-010.40  | 60           | 10          | 56       | 2200           | 38        | 260                    | 20                 |
| P-010.80  | 120          | 10          | 107      | 2400           | 20        | 510                    | 10                 |
| P-016.10  | 15           | 16          | 17       | 4600           | 320       | 180                    | 59                 |
| P-016.20  | 30           | 16          | 29       | 5500           | 190       | 340                    | 36                 |
| P-016.40  | 60           | 16          | 54       | 6000           | 100       | 680                    | 20                 |
| P-016.80  | 120          | 16          | 101      | 6500           | 54        | 1300                   | 11                 |
| P-016.90  | 180          | 16          | 150      | 6500           | 36        | 2000                   | 7                  |
| P-025.10  | 15           | 25          | 18       | 11000          | 740       | 400                    | 56                 |
| P-025.20  | 30           | 25          | 30       | 13000          | 440       | 820                    | 35                 |
| P-025.40  | 60           | 25          | 53       | 15000          | 250       | 1700                   | 21                 |
| P-025.80  | 120          | 25          | 101      | 16000          | 130       | 3400                   | 11                 |
| P-025.90  | 180          | 25          | 149      | 16000          | 89        | 5100                   | 7                  |
| P-025.150 | 250          | 25          | 204      | 16000          | 65        | 7100                   | 5                  |
| P-025.200 | 300          | 25          | 244      | 16000          | 54        | 8500                   | 5                  |
| P-035.10  | 15           | 35          | 20       | 20000          | 1300      | 700                    | 51                 |
| P-035.20  | 30           | 35          | 32       | 24000          | 810       | 1600                   | 33                 |
| P-035.40  | 60           | 35          | 57       | 28000          | 460       | 3300                   | 19                 |
| P-035.80  | 120          | 35          | 104      | 30000          | 250       | 6700                   | 11                 |
| P-035.90  | 180          | 35          | 153      | 31000          | 170       | 10000                  | 7                  |
| P-045.20  | 30           | 45          | 33       | 39000          | 1300      | 2800                   | 32                 |
| P-045.40  | 60           | 45          | 58       | 44000          | 740       | 5700                   | 19                 |
| P-045.80  | 120          | 45          | 105      | 49000          | 410       | 11000                  | 10                 |
| P-045.90  | 180          | 45          | 154      | 50000          | 280       | 17000                  | 7                  |
| P-050.20  | 30           | 50          | 33       | 48000          | 1600      | 3400                   | 32                 |
| P-050.40  | 60           | 50          | 58       | 55000          | 910       | 7000                   | 19                 |
| P-050.80  | 120          | 50          | 105      | 60000          | 500       | 14000                  | 10                 |
| P-050.90  | 180          | 50          | 154      | 61000          | 340       | 22000                  | 7                  |

|          | Displacement | Diameter OD | Length L | Blocking Force | Stiffness | Electrical Capacitance | Resonant Frequency |
|----------|--------------|-------------|----------|----------------|-----------|------------------------|--------------------|
| P-056.20 | 30           | 56          | 33       | 60000          | 2000      | 4300                   | 32                 |
| P-056.40 | 60           | 56          | 58       | 66000          | 1100      | 8900                   | 19                 |
| P-056.80 | 120          | 56          | 105      | 76000          | 630       | 18000                  | 10                 |
| P-056.90 | 180          | 56          | 154      | 78000          | 430       | 27000                  | 7                  |

Travel range: At 0 to 1000 V, tolerance -10 / 20 %.

Length L: Tolerance  $\pm 0.5$  mm.

Blocking force: At 0 to 1000 V.

Electrical capacitance: Tolerance  $\pm 20$  %, measured at  $1 V_{pp}$ , 1 kHz, RT.

Resonant frequency at  $1 V_{pp}$ , unloaded, unclamped. The value is halved for unilateral clamping.

Piezo ceramic type: PIC151.

Standard connections: FEP-insulated wire leads, 100 mm, AWG 24,  $\varnothing$  1.15 mm.

Operating voltage: 0 to 1000 V.

Operating temperature range: -20 to 85 °C.

Standard mechanical interfaces: Steel plates, 0.5 to 2 mm thick (depends on model)

Outer surface: Polyolefin shrink sleeving, black.

Recommended preload for dynamic operation: 15 MPa.

Maximum preload for constant force: 30 MPa.

Custom designs or different specifications on request.

### PICA Power piezo actuators

|           | Displacement | Diameter OD | Length L | Blocking Force | Stiffness  | Electrical Capacitance | Resonant Frequency |
|-----------|--------------|-------------|----------|----------------|------------|------------------------|--------------------|
|           | $\mu m$      | mm          | mm       | N              | N/ $\mu m$ | nF                     | kHz                |
| P-010.00P | 5            | 10          | 9        | 1200           | 240        | 17                     | 129                |
| P-010.10P | 15           | 10          | 18       | 1800           | 120        | 46                     | 64                 |
| P-010.20P | 30           | 10          | 31       | 2100           | 68         | 90                     | 37                 |
| P-010.40P | 60           | 10          | 58       | 2200           | 37         | 180                    | 20                 |
| P-010.80P | 120          | 10          | 111      | 2300           | 19         | 370                    | 10                 |
| P-016.10P | 15           | 16          | 18       | 4500           | 300        | 130                    | 64                 |
| P-016.20P | 30           | 16          | 31       | 5400           | 180        | 250                    | 37                 |
| P-016.40P | 60           | 16          | 58       | 5600           | 94         | 510                    | 20                 |
| P-016.80P | 120          | 16          | 111      | 5900           | 49         | 1000                   | 10                 |
| P-016.90P | 180          | 16          | 163      | 6000           | 33         | 1600                   | 7                  |
| P-025.10P | 15           | 25          | 20       | 9900           | 660        | 320                    | 58                 |
| P-025.20P | 30           | 25          | 33       | 12000          | 400        | 630                    | 35                 |
| P-025.40P | 60           | 25          | 60       | 13000          | 220        | 1300                   | 19                 |
| P-025.80P | 120          | 25          | 113      | 14000          | 120        | 2600                   | 10                 |
| P-025.90P | 180          | 25          | 165      | 14000          | 80         | 4000                   | 7                  |
| P-035.10P | 15           | 35          | 21       | 18000          | 1200       | 530                    | 55                 |
| P-035.20P | 30           | 35          | 34       | 23000          | 760        | 1200                   | 34                 |
| P-035.40P | 60           | 35          | 61       | 26000          | 430        | 2500                   | 19                 |
| P-035.80P | 120          | 35          | 114      | 28000          | 230        | 5200                   | 10                 |
| P-035.90P | 180          | 35          | 166      | 29000          | 160        | 7800                   | 7                  |
| P-045.20P | 30           | 45          | 36       | 36000          | 1200       | 2100                   | 32                 |
| P-045.40P | 60           | 45          | 63       | 41000          | 680        | 4300                   | 18                 |
| P-045.80P | 120          | 45          | 116      | 44000          | 370        | 8800                   | 10                 |
| P-045.90P | 180          | 45          | 169      | 45000          | 250        | 13000                  | 7                  |
| P-056.20P | 30           | 56          | 36       | 54000          | 1800       | 3300                   | 32                 |
| P-056.40P | 60           | 56          | 63       | 66000          | 1100       | 6700                   | 18                 |
| P-056.80P | 120          | 56          | 116      | 68000          | 570        | 14000                  | 10                 |
| P-056.90P | 180          | 56          | 169      | 70000          | 390        | 21000                  | 7                  |

Travel range: At 0 to 1000 V, tolerance -10 / 20 %.  
 Length L: Tolerance  $\pm 0.5$  mm.  
 Blocking force: At 0 to 1000 V.  
 Electrical capacitance: Tolerance  $\pm 20$  %, measured at 1 V<sub>pp</sub>, 1 kHz, RT.  
 Resonant frequency at 1 V<sub>pp</sub>, unloaded, unclamped. The value is halved for unilateral clamping.

Piezo ceramic type: PIC255.  
 Standard connections: FEP-insulated wire leads, 100 mm, AWG 24,  $\varnothing$  1.15 mm.  
 Operating voltage: 0 to 1000 V.  
 Operating temperature range: -20 to 150 °C.  
 Standard mechanical interfaces: Steel plates, 0.5 to 2 mm thick (depends on model)  
 Outer surface: FEP, transparent shrink sleeving  
 Recommended preload for dynamic operation: 15 MPa.  
 Maximum preload for constant force: 30 MPa.  
 Temperature sensor: PT 1000.

Custom designs or different specifications on request.

### PICA Thru ring actuators

|           | Displacement  | Diameter OD | Diameter ID | Length L | Blocking Force | Stiffness        | Electrical Capacitance | Resonant Frequency |
|-----------|---------------|-------------|-------------|----------|----------------|------------------|------------------------|--------------------|
|           | $\mu\text{m}$ | mm          | mm          | mm       | N              | N/ $\mu\text{m}$ | nF                     | kHz                |
| P-010.00H | 5             | 10          | 5           | 7        | 1200           | 230              | 15                     | 144                |
| P-010.10H | 15            | 10          | 5           | 15       | 1700           | 110              | 40                     | 67                 |
| P-010.20H | 30            | 10          | 5           | 27       | 1800           | 59               | 82                     | 39                 |
| P-010.40H | 60            | 10          | 5           | 54       | 1800           | 29               | 180                    | 21                 |
| P-016.00H | 5             | 16          | 8           | 7        | 2900           | 580              | 42                     | 144                |
| P-016.10H | 15            | 16          | 8           | 15       | 4100           | 270              | 120                    | 67                 |
| P-016.20H | 30            | 16          | 8           | 27       | 4500           | 150              | 230                    | 39                 |
| P-016.40H | 60            | 16          | 8           | 52       | 4700           | 78               | 490                    | 21                 |
| P-025.10H | 15            | 25          | 16          | 16       | 7400           | 490              | 220                    | 63                 |
| P-025.20H | 30            | 25          | 16          | 27       | 8700           | 290              | 430                    | 39                 |
| P-025.40H | 60            | 25          | 16          | 51       | 9000           | 150              | 920                    | 22                 |
| P-025.50H | 80            | 25          | 16          | 66       | 9600           | 120              | 1200                   | 17                 |

Travel range: At 0 to 1000 V, tolerance -10 / 20 %.  
 Length L: Tolerance  $\pm 0.5$  mm.  
 Blocking force: At 0 to 1000 V.  
 Electrical capacitance: Tolerance  $\pm 20$  %, measured at 1 V<sub>pp</sub>, 1 kHz, RT.  
 Resonant frequency at 1 V<sub>pp</sub>, unloaded, unclamped. The value is halved for unilateral clamping.

Piezo ceramic type: PIC151.  
 Standard connections: FEP-insulated wire leads, 100 mm, AWG 24,  $\varnothing$  1.15 mm.  
 Operating voltage: 0 to 1000 V.  
 Operating temperature range: -20 to 85 °C.  
 Standard mechanical interfaces: Ceramic rings (passive PZT).  
 Outer surface: Polyolefin shrink sleeving, black (outside); epoxy resin (inside).  
 Recommended preload for dynamic operation: 15 MPa.  
 Maximum preload for constant force: 30 MPa.

Custom designs or different specifications on request.

## 10.1.2 Maximum Ratings

P-0xx piezo actuators are designed for the operating data given in the table below.

### Additional information on the maximum ratings table

- Maximum operating frequency without load, without considering thermal aspects, column A:





The values apply to unilaterally clamped piezo actuators and are calculated as follows: A third of the resonant frequency of the unloaded piezo actuator (operation when not clamped on both sides) divided by two. For further restrictions, see "Overview of Limiting Factors" (p. 41).





- Maximum operating frequency without load, considering thermal aspects, column B:





In order to prevent the maximum permissible operating temperature from being exceeded, the operating frequency of the unloaded, **uncooled** piezo actuator must not exceed the given frequency when the operating voltage is **1000 V peak-to-peak**. In the case of smaller amplitudes of the operating voltage and/or the use of cooling measures, higher operating frequencies are possible. For further restrictions, see "Overview of Limiting Factors" (p. 41).

- Maximum power consumption:

Power consumption of the unloaded, uncooled piezo actuator that is operated at an operating voltage of **1000 V peak-to-peak** with the operating frequency from column B of this table.

| Piezo Actuator | Maximum Operating Voltage Range   | Maximum Operating Frequency without Load  |  | Maximum Power Consumption   |
|----------------|---|---|--|---|
|                |   | A:<br>Without Considering Thermal Aspects   | B:<br>Considering Thermal Aspects  |   |
|                |  |  |  |  |
| P-007.00       | 0 V to 1000 V   | 21 kHz  | 112 Hz   | 1.6 W   |
| P-007.10       | 0 V to 1000 V   | 9.8 kHz   | 78 Hz  | 3.5 W   |
| P-007.20       | 0 V to 1000 V   | 6 kHz   | 69 Hz  | 5.9 W   |
| P-007.40       | 0 V to 1000 V   | 3.3 kHz   | 64 Hz  | 11 W  |
| P-010.00       | 0 V to 1000 V   | 21 kHz  | 86 Hz  | 2.4 W   |
| P-010.10       | 0 V to 1000 V   | 9.8 kHz   | 61 Hz  | 5.1 W   |
| P-010.20       | 0 V to 1000 V   | 5.8 kHz   | 52 Hz  | 9.1 W   |
| P-010.40       | 0 V to 1000 V   | 3.3 kHz   | 49 Hz  | 17 W  |
| P-010.80       | 0 V to 1000 V   | 1.7 kHz   | 47 Hz  | 32 W  |
| P-016.10       | 0 V to 1000 V   | 9.8 kHz   | 34 Hz  | 8 W   |
| P-016.20       | 0 V to 1000 V   | 6 kHz   | 31 Hz  | 14 W  |
| P-016.40       | 0 V to 1000 V   | 3.3 kHz   | 29 Hz  | 26 W  |
| P-016.80       | 0 V to 1000 V   | 1.8 kHz   | 28 Hz  | 48 W  |

| Piezo Actuator | Maximum Operating Voltage Range<br> | Maximum Operating Frequency without Load   |   | Maximum Power Consumption<br>Considering Thermal Aspects<br> |
|----------------|--|--|---|---|
|                |  | A:<br>Without Considering Thermal Aspects<br> | B:<br>Considering Thermal Aspects<br> |   |
| P-016.90       | 0 V to 1000 V  | 1.2 kHz  | 27 Hz   | 72 W  |
| P-025.10       | 0 V to 1000 V  | 9.3 kHz  | 25 Hz   | 14 W  |
| P-025.20       | 0 V to 1000 V  | 5.8 kHz  | 21 Hz   | 23 W  |
| P-025.40       | 0 V to 1000 V  | 3.5 kHz  | 18 Hz   | 40 W  |
| P-025.80       | 0 V to 1000 V  | 1.8 kHz  | 17 Hz   | 76 W  |
| P-025.90       | 0 V to 1000 V  | 1.2 kHz  | 17 Hz   | 113 W   |
| P-025.150      | 0 V to 1000 V  | 0.8 kHz  | 16 Hz   | 154 W   |
| P-025.200      | 0 V to 1000 V  | 0.8 kHz  | 16 Hz   | 184 W   |
| P-035.10       | 0 V to 1000 V  | 8.5 kHz  | 22 Hz   | 21 W  |
| P-035.20       | 0 V to 1000 V  | 5.5 kHz  | 16 Hz   | 33 W  |
| P-035.40       | 0 V to 1000 V  | 3.2 kHz  | 13 Hz   | 59 W  |
| P-035.80       | 0 V to 1000 V  | 1.8 kHz  | 12 Hz   | 108 W   |
| P-035.90       | 0 V to 1000 V  | 1.2 kHz  | 12 Hz   | 159 W   |
| P-045.20       | 0 V to 1000 V  | 5.3 kHz  | 12 Hz   | 44 W  |
| P-045.40       | 0 V to 1000 V  | 3.2 kHz  | 10 Hz   | 78 W  |
| P-045.80       | 0 V to 1000 V  | 1.7 kHz  | 10 Hz   | 141 W   |
| P-045.90       | 0 V to 1000 V  | 1.2 kHz  | 9 Hz  | 207 W   |
| P-050.20       | 0 V to 1000 V  | 5.3 kHz  | 11 Hz   | 50 W  |
| P-050.40       | 0 V to 1000 V  | 3.2 kHz  | 9 Hz  | 88 W  |
| P-050.80       | 0 V to 1000 V  | 1.7 kHz  | 8 Hz  | 159 W   |
| P-050.90       | 0 V to 1000 V  | 1.2 kHz  | 8 Hz  | 233 W   |
| P-056.20       | 0 V to 1000 V  | 5.3 kHz  | 10 Hz   | 56 W  |
| P-056.40       | 0 V to 1000 V  | 3.2 kHz  | 8 Hz  | 99 W  |
| P-056.80       | 0 V to 1000 V  | 1.7 kHz  | 7 Hz  | 179 W   |
| P-056.90       | 0 V to 1000 V  | 1.2 kHz  | 7 Hz  | 263 W   |
| P-010.00P      | 0 V to 1000 V  | 21.5 kHz   | 101 Hz  | 2.4 W   |
| P-010.10P      | 0 V to 1000 V  | 10.7 kHz   | 76 Hz   | 4.7 W   |
| P-010.20P      | 0 V to 1000 V  | 6.2 kHz  | 67 Hz   | 8.1 W   |
| P-010.40P      | 0 V to 1000 V  | 3.3 kHz  | 63 Hz   | 15.2 W  |
| P-010.80P      | 0 V to 1000 V  | 1.7 kHz  | 59 Hz   | 29.1 W  |
| P-016.10P      | 0 V to 1000 V  | 10.7 kHz   | 43 Hz   | 7.5 W   |
| P-016.20P      | 0 V to 1000 V  | 6.2 kHz  | 39 Hz   | 12.9 W  |
| P-016.40P      | 0 V to 1000 V  | 3.3 kHz  | 35 Hz   | 24 W  |
| P-016.80P      | 0 V to 1000 V  | 1.7 kHz  | 35 Hz   | 46 W  |
| P-016.90P      | 0 V to 1000 V  | 1.2 kHz  | 32 Hz   | 68 W  |
| P-025.10P      | 0 V to 1000 V  | 9.7 kHz  | 31 Hz   | 13 W  |
| P-025.20P      | 0 V to 1000 V  | 5.8 kHz  | 26 Hz   | 22 W  |
| P-025.40P      | 0 V to 1000 V  | 3.2 kHz  | 23 Hz   | 39 W  |
| P-025.80P      | 0 V to 1000 V  | 1.7 kHz  | 21 Hz   | 74 W  |
| P-025.90P      | 0 V to 1000 V  | 1.2 kHz  | 20 Hz   | 109 W   |
| P-035.10P      | 0 V to 1000 V  | 9.2 kHz  | 27 Hz   | 19 W  |
| P-035.20P      | 0 V to 1000 V  | 5.7 kHz  | 19 Hz   | 31 W  |
| P-035.40P      | 0 V to 1000 V  | 3.2 kHz  | 16 Hz   | 55 W  |
| P-035.80P      | 0 V to 1000 V  | 1.7 kHz  | 15 Hz   | 102 W   |
| P-035.90P      | 0 V to 1000 V  | 1.2 kHz  | 14 Hz   | 149 W   |
| P-045.20P      | 0 V to 1000 V  | 5.3 kHz  | 15 Hz   | 42 W  |
| P-045.40P      | 0 V to 1000 V  | 3 kHz  | 13 Hz   | 74 W  |
| P-045.80P      | 0 V to 1000 V  | 1.7 kHz  | 12 Hz   | 135 W   |
| P-045.90P      | 0 V to 1000 V  | 1.2 kHz  | 11 Hz   | 197 W   |
| P-056.20P      | 0 V to 1000 V  | 5.3 kHz  | 12 Hz   | 53 W  |

| Piezo Actuator | Maximum Operating Voltage Range<br> | Maximum Operating Frequency without Load   |   | Maximum Power Consumption<br>Considering Thermal Aspects<br> |
|----------------|--|--|---|---|
|                |  | A:<br>Without Considering Thermal Aspects<br> | B:<br>Considering Thermal Aspects<br> |   |
| P-056.40P      | 0 V to 1000 V  | 3 kHz  | 10 Hz   | 93 W  |
| P-056.80P      | 0 V to 1000 V  | 1.7 kHz  | 9 Hz  | 172 W   |
| P-056.90P      | 0 V to 1000 V  | 1.2 kHz  | 9 Hz  | 250 W   |
| P-010.00H      | 0 V to 1000 V  | 24 kHz   | 82 Hz   | 2 W   |
| P-010.10H      | 0 V to 1000 V  | 11.2 kHz   | 63 Hz   | 3 W   |
| P-010.20H      | 0 V to 1000 V  | 6.5 kHz  | 56 Hz   | 6 W   |
| P-010.40H      | 0 V to 1000 V  | 3.5 kHz  | 51 Hz   | 12 W  |
| P-016.00H      | 0 V to 1000 V  | 24 kHz   | 45 Hz   | 3 W   |
| P-016.10H      | 0 V to 1000 V  | 11.2 kHz   | 34 Hz   | 5 W   |
| P-016.20H      | 0 V to 1000 V  | 6.5 kHz  | 32 Hz   | 10 W  |
| P-016.40H      | 0 V to 1000 V  | 3.5 kHz  | 29 Hz   | 19 W  |
| P-025.10H      | 0 V to 1000 V  | 10.5 kHz   | 24 Hz   | 7 W   |
| P-025.20H      | 0 V to 1000 V  | 6.5 kHz  | 21 Hz   | 12 W  |
| P-025.40H      | 0 V to 1000 V  | 3.7 kHz  | 19 Hz   | 23 W  |
| P-025.50H      | 0 V to 1000 V  | 2.8 kHz  | 18 Hz   | 29 W  |

### 10.1.3 Compressive/Tensile Stress Capacity and Preload

Piezo ceramic withstands a pressure of up to 250 MPa but starts to depolarize at significantly lower compressive loads. Since, in addition, stacked piezo actuators are manufactured from different materials (e.g. piezo ceramic, metallic electrodes, epoxide), the mechanical load capacity does not depend solely on the strength of the ceramic material. Consideration must be given to additional parameters such as slenderness ratio, bending, tilt and homogeneity of the force application.

The tensile stress capacity of piezo actuators is just 5 to 10 % of the compressive load capacity. It is therefore recommended to mechanically preload the actuators. The preload should be chosen only as high as necessary.

#### Compressive/tensile stress capacity and preload of the P-0xx

| Type of Mechanical Stress                       | P-0xx*  |
|---|---------|
| Maximum compressive load capacity               | 30 MPa  |
| Maximum tensile stress capacity without preload | 2 MPa** |
| Recommended preload for dynamic operation       | 15 MPa  |
| Maximum preload for constant force              | 30 MPa  |

\*1 MPa corresponds to a pressure of 1 N per square millimeter of the base area of the piezo actuator. For actuator diameters, see the data table (p. 55).

\*\*Depends on the strength of the glued connections (p. 26)



### 10.1.4 Ambient Conditions and Classifications

The following ambient conditions and classifications must be observed for the P-0xx:

|                       |   |
|-----------------------|---|
| Area of application   | For indoor use only   |
| Air pressure          | >500 hPa or <1 hPa  |
| Relative humidity     | Maximum relative humidity 50 %<br>Continuous operation with high static voltage in humid environments significantly reduces piezo actuator lifetime.<br>➤ Observe the information on lifetime in "General Notes on Start-Up and Operation" (p. 35). |
| Operating temperature | Models P-007 - P-056 and models P-010.xxH - P-025.xxH:<br>-20 °C to 85 °C<br>Models P-010.xxP - P-056.xxP:<br>-20 °C to 150 °C  |
| Storage temperature   | -20 °C to 80 °C   |
| Transport temperature | -20 °C to 80 °C   |
| Overvoltage category  | II  |
| Degree of pollution   | 1   |

The P-0xx is intended for installation in devices that fulfil the following classifications:

|   |      |
|---|------|
| Protection class                            | I    |
| Degree of protection according to IEC 60529 | IP20 |

## 10.2 Dimensions

Dimensions in mm.

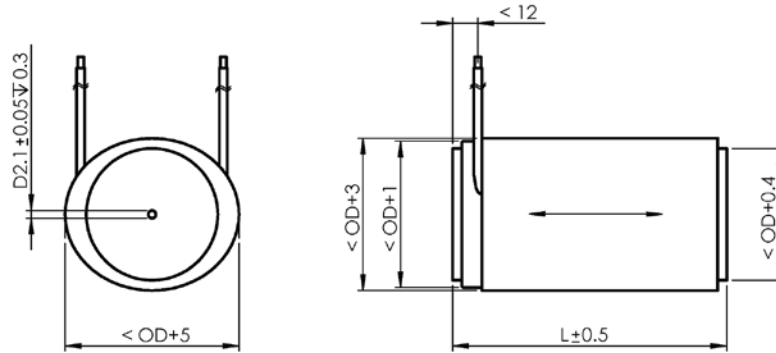

Figure 14: P-007 - P-056 (PICA Stack): L, OD see data table

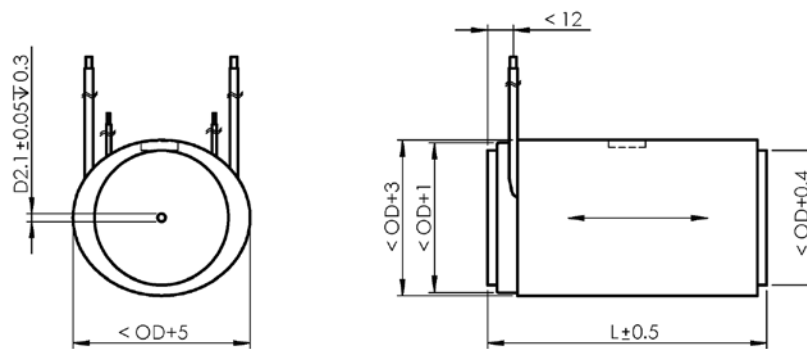

Figure 15: P-010.xxP - P-056.xxP (PICA Power): L, OD see data table

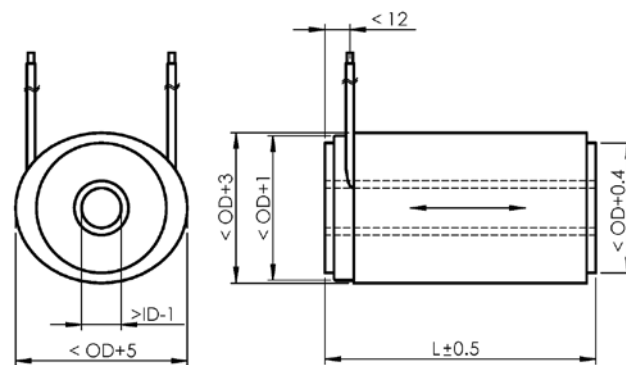

Figure 16: P-010.xxH - P-025.xxH (PICA Thru): L, ID, OD see data table

## 11 Old Equipment Disposal

In accordance with applicable EU law, electrical and electronic equipment must not be disposed of in the member states of the EU with other wastes.

When disposing of your old equipment, observe the international, national and local rules and regulations.

To meet the manufacturer's product responsibility with regard to this product, PI Ceramic GmbH ensures environmentally correct disposal of old PI equipment that was first put into circulation after 13 August 2005, free of charge.

If you have old PI equipment, you can send it postage-free to the following address:

PI Ceramic GmbH  
Lindenstrasse  
D-07589 Lederhose





## 12 EC Declaration of Conformity

For the P-0xx, an EC Declaration of Conformity has been issued in accordance with the following European directives:

2011/65/EU, RoHS Directive

The applied standards certifying the conformity are listed below.

RoHS: EN 50581:2012

If an electrical operating device is designed to be integrated in another electrical operating device: The operator is responsible for a standards compliant integration of the electrical device into the overall system.

